

Installation Instructions and Homeowner's Manual

DOMESTIC WATER HEATER OIL FIRED

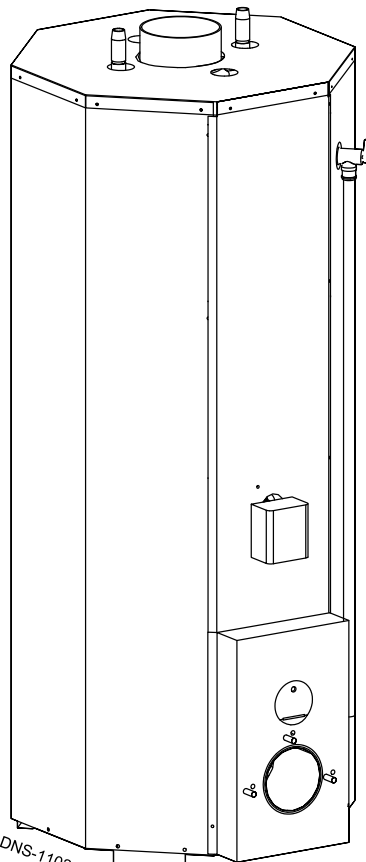

CMO32-II & CMO32-II-R

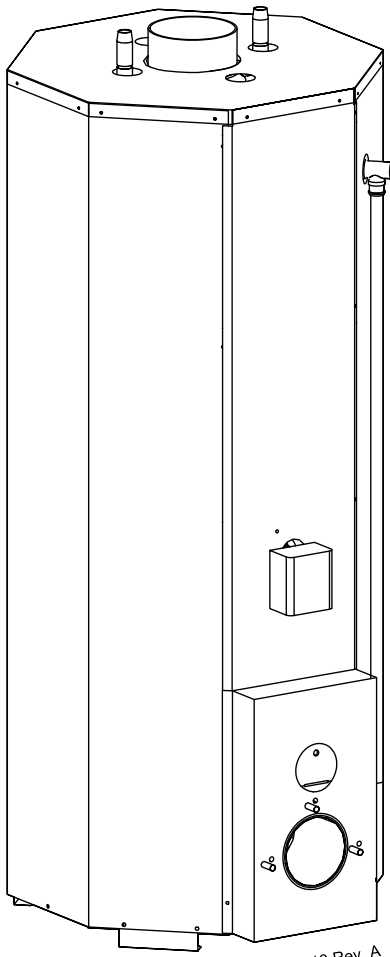

CMO50-II

INSTALLER / SERVICE TECHNICIAN:

USE THE INFORMATION IN THIS MANUAL FOR THE INSTALLATION AND SERVICING OF THE FURNACE AND KEEP THE DOCUMENT NEAR THE UNIT FOR FUTURE REFERENCE.

HOMEOWNER:

PLEASE KEEP THIS MANUAL NEAR THE FURNACE FOR FUTURE REFERENCE.

Models :

**CMO32-II
CMO32-II-R
CMO50-II**



Caution: Do not tamper with the unit or its controls. Call a qualified service technician.

Manufactured by :
Industries Dettson inc.

Sherbrooke, Québec - Canada

www.dettson.ca

TABLE OF CONTENTS

1.0	SAFETY REGULATIONS	3
1.1	DANGER, WARNING AND CAUTION.....	3
1.2	SAFETY INSTALLATION REQUIREMENTS	3
2.0	INSTALLATION	4
2.1	LOCATION.....	4
2.2	ACCESS FOR MAINTENANCE.....	4
2.3	SHIPPING COMPONENTS	4
2.4	WATER CONNECTIONS.....	4
2.5	FLUE PIPE.....	4
2.6	DRAFT REGULATOR.....	4
2.7	BLOCKED VENT SHUT-OFF (BVSO)	4
2.8	CHIMNEY.....	4
2.9	CONTROLS	4
2.10	WIRING	4
2.11	COMBUSTION PRIMARY CONTROL (ON BURNER)	5
2.12	INSTALLING THE OIL BURNER	5
2.13	NOZZLE DATA	5
2.14	FUEL OIL PUMP.....	5
2.15	OIL TANK AND PIPING.....	5
2.16	VENTILATION AND COMBUSTION AIR.....	5
3.0	OPERATION	5
3.1	INITIAL START-UP	5
3.2	ADJUSTMENTS.....	5
3.3	SHUT-DOWN.....	5
3.4	BVSO PERFORMANCE TEST	6
3.5	FLAME FAILURE	6
4.0	MAINTENANCE	6
4.1	GENERAL.....	6
4.2	BLOCKED VENT SHUT OFF (BVSO) CLEANING.....	6
4.3	CLEANING.....	6
4.4	COMBUSTION CHAMBER REPLACEMENT	7
5.0	FURNACE INFORMATION	8
6.0	TECHNICAL DATA	9
7.0	REPLACEMENT PARTS	11

FIGURES

Figure 1 : Electrical wiring, Beckett burner	10
Figure 2 : Electrical wiring, Riello burner	10
Figure 3 : Parts List, Model 32.....	11
Figure 4 : Parts List, Model 50.....	12

TABLES

Table 1 : Minimum clearances.....	4
Table 2 : Technical specifications	9
Table 3 : Parts List, Model 32.....	11
Table 4 : Parts List, Model 50.....	12

1.0 SAFETY REGULATIONS

FOR YOUR SAFETY

DO NOT STORE OR USE GASOLINE OR OTHER FLAMMABLE VAPOURS AND LIQUIDS IN THE VICINITY OF THIS OR ANY OTHER APPLIANCE.

DO NOT ATTEMPT TO START THE BURNER WHEN EXCESS OIL HAS ACCUMULATED, WHEN THE FURNACE IS FULL OF VAPOUR OR WHEN THE COMBUSTION CHAMBER IS VERY HOT.

1.1 DANGER, WARNING AND CAUTION

The words DANGER, WARNING and CAUTION are used to identify the levels of seriousness of certain hazards. It is important that you understand their meaning. You will notice these words in the manual as follows:



DANGER

Immediate hazards which WILL result in death or serious bodily and/or material damage.



WARNING

Hazards or unsafe practices which CAN result in death or serious bodily and /or material damage.



CAUTION

Hazards or unsafe practices which CAN result in minor bodily and /or material damage.

1.2 SAFETY INSTALLATION REQUIREMENTS



WARNING

Installation or repairs performed by unqualified persons can result in hazards to them and others. Installation **MUST** conform to local codes or, in the absence of same, to codes of the country having jurisdiction.

The information contained in this manual is intended for use by a qualified service technician familiar with safety procedures and quipped with the proper tools and test instruments.

Failure to carefully read and follow all instructions in this manual can result in death, furnace malfunction and/or property damage.



WARNING

For use with grade 2 fuel oil maximum. Do NOT use gasoline, crankcase oil or any oil containing gasoline.



WARNING

Never burn garbage or paper in the heating system and never leave rags or paper around the unit.

- a. It is the homeowner's responsibility to engage a qualified technician for the installation and subsequent servicing of this water heater;
- b. Do not use this appliance if any part of it was under water. Call a qualified service technician immediately, to assess the damage and to replace all critical parts that were in contact with water;
- c. Ask the technician installing your water heater to show and explain to you the following items:
 - i) The main disconnect switch
 - ii) The shut-off valve on the oil tank;
 - iii) The oil filter and how to change is (once a year);
- d. Before calling for service, be sure to have the information page of your manual close by, in order to be able to provide the contractor with the required information, such as the model and serial numbers of the water heater.

IMPORTANT: All local and national code requirements governing the installation of oil burning equipment, wiring and flue connections must be followed. Some of the codes that may be applicable are:

CSA B139	Installation Code for Oil Burning Equipment
NFPA 31	Installation of Oil Burning Equipment
ANSI/NFPA 70	National Electrical Code
CSA C22.1	Canadian Electrical Code

Only the latest issues of the above codes should be used, and are available from either:

The Canadian Standards Association
178 Rexdale Blvd.
Rexdale, Ontario M9W 1R3



CAUTION

ENVIRONMENTAL HAZARD

Failure to follow this caution may result in environmental pollution.

Remove and recycle all components or materials (i.e. oil, electrical and electronic components, insulation, etc.) before unit final disposal.

2.0 INSTALLATION

2.1 LOCATION

The water heater must be installed on a level and **NON-COMBUSTIBLE** surface, as close as possible to the chimney. The water heater must also be located close to a suitable free-flowing floor drain. Where a floor drain is not adjacent to the water heater, a suitable drain pan must be installed under the water heater. This drain pan should be at least 4" (10,2 cm) larger than the diameter of the water heater, and at least 1" (2,5 cm) deep providing access to the drain valve. This pan must be piped to a suitable drain to prevent damage to property in the event of a water leak from the piping, the relief valve, or the water heater.

Sooner or later, all water heaters leak. The manufacturer, based on national building codes has given the necessary advice to prevent damage to the building. Under no circumstances is the manufacturer to be held liable for any water damage in connection with this water heater.

Note: If the temperature in the house and/or the basement is under 16°C (60°F) there is an increased possibility of condensation inside the chimney.

2.2 ACCESS FOR MAINTENANCE

Convenient access shall be provided to permit cleaning of heating surfaces, flue pipe and for burner maintenance. Minimum clearances from combustible material should be:

Table 1 : Minimum clearances

	Models 32 and 50
Sides	5,08 cm (2")
Rear	5,08 cm (2")
Top	45,70 cm (18")
Front	61,00 cm (24")
Flue	22,90 cm (9")

2.3 SHIPPING COMPONENTS

The unit is shipped in two separate cartons; the first carton is for the water heater tank. The second is for the burner the aquastat, the wiring harness and the flue adaptor.

2.4 WATER CONNECTIONS



WARNING

To avoid water damage and/or scalding due to relief valve operation, a discharge line must be connected to the valve outlet and run to a drainage area. The discharge line shall be installed in such a way that it will allow for complete drainage of the valve and discharge line.

Make the hot and cold water connections to the water heater. Do not apply heat to the hot water outlet and cold water inlet, as they contain a plastic sleeve inside. Pressure relief valves are installed on all models.

2.5 FLUE PIPE

The water heater should be connected to a chimney or an approved pre-fabricated flue. The flue pipe should be the

same size as the flue outlet of the unit. It is preferable to maintain a pitch or rise from the heater to the chimney of 2.0 cm per 1 m (1/4" per foot). The flue pipe must not be extended past the inside wall of the chimney.

2.6 DRAFT REGULATOR

The draft regulator must be installed between the flue outlet of the water heater and the chimney. (Installation instructions are furnished with the regulator).

2.7 BLOCKED VENT SHUT-OFF (BVSO)

For chimney venting



WARNING

It is imperative that this device be installed by a qualified technician.

This device is designed to detect the insufficient evacuation of combustion gases in the event of a vent blockage. In such a case the thermal switch will shut down the oil burner. The device will then need to be re-armed MANUALLY.

Refer to the wiring diagrams and the detailed instructions supplied with the BVSO for the installation and wiring procedure. The length of wires supplied with the unit is such that the safety device must be installed between the flue outlet of the appliance and the draft regulator, as indicated in the instructions.

It is further imperative that the BVSO be maintained annually. Refer to the instructions supplied with the device and paragraph 4.2 of this manual for more details.

2.8 CHIMNEY

For information pertaining to chimney sizes, elevation, conditions, etc., see C.S.A. Standard B-139, "Installation code for oil burning equipment."



WARNING

An oil-fired unit shall be connected to a flue having sufficient draft at all times to assure proper operation of the unit.

2.9 CONTROLS

Mount the aquastat control on the unit. Set operating control between 48°C (120°F) and 60°C (140°F). The maximum setting for all models is 60°C (140°F). If required, set the high-limit at a temperature of 20 ° F higher than the operating control.

2.10 WIRING

Connect BX harness from aquastat to the side of the burner relay junction box. Wire oil burner and controls according to the attached wiring diagram. The field supplied wiring should be connected to the top of the aquastat on all models.

2.11 COMBUSTION PRIMARY CONTROL (ON BURNER)

The purpose of this control is to sequence the operation of the burner. The first function is to close the burner circuit and the ignition transformer circuit when the aquastat calls for heat and also to open the burner circuit when the water temperature is attained. The second function is to shut-off the oil burner in the case of lack of ignition, oil, flame, proper voltage or due to burner malfunction.

2.12 INSTALLING THE OIL BURNER

The nozzle is installed on the burner. Make sure to adjust the nozzle and electrode as per Table 2. Mount burner on water heater and use the gasket supplied, between burner mounting flange and the water heater.

When reusing a compatible burner in good condition, verify the insertion length and adjust the burner flange accordingly. Always change the nozzle for a new one as specified on the nameplate.



CAUTION

Riello burners requires a ceramic felt sleeve (amulet #N05F016 over the tube. If this caution is not observed, the warranty is null and void.

2.13 NOZZLE DATA

Refer to the Technical Specifications (Table 2).

2.14 FUEL OIL PUMP

The fuel oil pump is developed for pressure atomizing type oil burner service and has a built-in pressure regulating valve and oil filter. Connections are provided for both, a one pipe system and a two pipe system. Pump pressure is gauged at the factory. This is the proper working pressure and should be checked with a suitable gauge at the spot indicated on the pump.

2.15 OIL TANK AND PIPING

The oil tank must be installed on a suitable base in order to prevent settling and the foundation must be of non-flammable material. A manual shut-off valve and an oil filter must be installed in the oil supply line located at the outlet of the oil tank. Use properly sized oil supply lines for installation. Consult the latest C.S.A. code and supplements for installation of oil burning equipment. An oil return line must be used on an installation where the oil level of the tank is below the burner. This return line must be the same size as the suction line.

At the beginning of every heating season have a qualified service technician check the entire oil distribution system for leaks.

2.16 VENTILATION AND COMBUSTION AIR

Normally, infiltration of air into the home is adequate to provide the necessary volume of air for combustion and ventilation. When a unit is installed in a room under high negative pressure conditions, provisions should be made for an outside source of combustion air. If the unit is located in

an enclosed area, two openings are required, one near the floor and the other near the ceiling. Each opening should have a minimum area of one square inch per 1,000 BTU/h, free of any obstruction. In the case of an outside wall, only one opening is required. This opening must be protected by a louver to prevent snow or rain penetration. A minimum area of one square inch per 5,000 BTU/h is required and must be free of any obstruction.

3.0 OPERATION

3.1 INITIAL START-UP

1. Turn-off the electric switch, which controls the water heater (see that proper fuses are installed, max: 15 amps);
2. Fill the water heater (leave inlet water valve open);
3. Carefully check for water leaks;
4. Open manual shut-off valve from oil tank to burner;
5. Adjust the combustion air band or set the damper to a quarter open position;
6. Press the reset button on the combustion safety relay **ONCE ONLY** (relay is mounted on burner);
7. Turn the switch to "ON" (burner should start);
8. Purge the oil line through the valve located near the pump (refer to the instructions enclosed with the burner).
9. Carefully check for oil leaks.

3.2 ADJUSTMENTS



CAUTION

In order for the manufacturer's warranty to apply, the oil burner must be adjusted between No. 0 and 1 of smoke density. There must also be a minimum draft of -0.02" w.c. at the vent connector. These adjustments must be made with a Bacharach instrument or equivalent. If not, the warranty is null and void.

1. Adjust the draft regulator to obtain a minimum of -0.02" W.C. The reading must be taken between the water heater flue outlet and the draft regulator;
2. Adjust the combustion air band to produce a No. 1 smoke spot maximum on the Bacharach scale. The reading must be taken only when the combustion chamber is hot and the observation door is closed;
3. Set the operating and the Limit Control as previously specified.

3.3 SHUT-DOWN

1. Turn off power to the unit.
2. Close oil valve at oil storage tank.

Note: Always keep the fuel supply valve closed if the burner is shut-down for an extended period of time.

3.4 BVSO PERFORMANCE TEST

The purpose of the following test is to check that the electrical outlet on the furnace, designated to the BVSO, is functional.

1. Start up the burner;
2. Remove the three-pole plug from the BVSO outlet on the furnace;
3. The burner must shut-off immediately.
4. If the test is not in line with the above, **call a qualified service technician.**

3.5 FLAME FAILURE

1. Wait at least five minutes before pushing the safety control;
2. Check fuses or breakers;
3. Check oil level in the tank and make sure that the oil valve is open (if the tank is empty, have it filled and purge the oil line);
4. Make sure that the aquastat is set above water temperature;
5. Reset the safety control **ONCE ONLY**;
6. If the burner still does not start, **call a qualified service technician.**

4.0 MAINTENANCE

4.1 GENERAL

1. The water heater and flue pipe should be cleaned, once a year;
2. The unit should be flushed monthly and in the case of hard water areas, more often;
3. **The anodes should be inspected annually, and if necessary, replaced. (The anodes have a life expectancy from one to ten years depending on water conditions);**



CAUTION

The warranty will be void if the anodes are not replaced.

4. The nozzle should be inspected and if necessary, removed and replaced. Handle nozzle with care so that the inside surface of the tip is not scratched.
5. The electrodes should be cleaned and adjusted according to the burner manufacturer's specifications;
6. Do not lubricate the oil burner motor, it is permanently lubricated;
7. The oil filter should be changed annually:
 - a) Place a pan under strainer and remove strainer cover, taking care not to damage gaskets.
 - b) Take out strainer cartridge and replace it annually.
 - c) Re-assemble strainer.

4.2 BLOCKED VENT SHUT OFF (BVSO) CLEANING

For continued safe operation, the Blocked Vent Shut-Off System (BVSO) needs to be inspected and maintained annually by a qualified service technician.



WARNING

ELECTRICAL SHOCK HAZARD

Failure to follow this warning could result in personal injury or death.

Disconnect electrical power supply to the furnace before servicing the blocked vent shut-off.

1. Remove the two screws holding down the BVSO assembly cover;
2. Remove the cover;
3. Remove the two screws holding the control box to the heat transfer tube assembly. Sliding the control box in the appropriate direction will unlock it from the heat transfer tube assembly;
4. Carefully remove any build-up from the thermal switch surface;



CAUTION

Do not dent or scratch the surface of the thermal switch. If the thermal switch is damaged, it must be replaced.

5. Clear and remove any build-up or obstruction inside the heat transfer tube;
6. Re-mount, lock and fasten the control box with the 2 screws removed in step 3;
7. Re-attach the assembly cover with the screws removed in step 1;
8. Re-establish power to the appliance.

4.3 CLEANING

1. Turn main power switch "OFF";
2. Close oil valve at oil storage tank;
3. Remove flue pipe from water heater flue outlet;
4. Clean flue pipe with wire brush and vacuum;
5. Remove oil burner from water heater and inspect combustion chamber;
6. Remove the screws holding the transformer to the casing and swing transformer back on its hinges;
7. Disconnect and remove the tubing from the nozzle by removing the nut;
8. Pull out the assembly;
9. Clean the nozzle inside the burner blast tube;
10. Check to see that the nozzle and electrode settings are correct (see burner manufacturer's specifications);
11. Re-install assembly by reversing the above procedure.

4.4 COMBUSTION CHAMBER REPLACEMENT

To replace the combustion chamber, follow these steps:

1. Turn off the power to the unit;
2. Remove the burner and the access panel. Cut the insulation and unscrew outer liner;
3. Take off the insulation pad and remove the damaged chamber by sliding it out;
4. Install the new chamber.
5. Re-install insulation, outer liner, access panel and burner. Ensure that the insulation completely encloses the space between the combustion chamber and the tank.

When ordering replacement parts, always indicate the model number, which is located on the rating plate.

5.0 FURNACE INFORMATION

Model: _____ Serial number: _____

Installation date: _____

Service telephone - Day: _____ Night: _____

Dealer name and address: _____

START-UP TEST RESULTS

CO²: _____ Stack temp.: _____

Firing rate: _____ GPH Smoke: _____

Draft - at stack: _____

Test performed by: _____

6.0 TECHNICAL DATA

Table 2 : Technical specifications

RATING AND PERFORMANCE	CMO32-II		CMO32-II-R		CMO50-II	
Burner insertion sleeve length	5 1/2"		4 3/4"		5 1/2"	
Firing rate (USGPH)	0.65	0.75	0.65	0.75	0.65	0.75
Input (BTU/h)	91 000	105 000	91 000	105 000	91 000	105 000
Capacity (BTU/h)	70 000	83 000	70 000	83 000	70 000	83 000
1st hour rate at 55.6°C (100°F) temperature rise	125 USG	183 USG	125 USG	183 USG	154 USG	198 USG
Flue draft	-0.02" W.C.		-0.02" W.C.		-0.02" W.C.	
BECKETT BURNER AFG-F0 (4 slot air shutter - insertion 5 5/8") - PART # B10273						
Nozzle Delavan	0.65-80W				0.65-80W	
Pump pressure (psi)	100				100	
Air settings	7/0				7/0	
ATC	AF65B0				AF65B0	
Low firing rate baffle	YES				YES	
Static disc, model	3 3/8"R				3 3/8"R	
BECKETT BURNER AFG-F3 (8 slot air shutter - insertion 5 1/2")						
Nozzle Delavan	0.65-80B					
Pump pressure (psi)	100					
Air settings	3/0					
ATC	AF72YH					
Low firing rate baffle	YES					
Static disc, model	3 3/8"U					
RIELLO BURNER 40-F3 (insertion 5 5/8") - PART # B10435 WITH AMULET #N05F016						
Nozzle Delavan		0.65-70A				0.65-70A
Pump pressure		135				135
Combustion air adjustment (turbulator/damper)		0 / 3.5				0 / 3.5
RIELLO BURNER R35.3 (insertion 4 3/4") - PART # N01F057 WITH AMULET #N05F016						
Nozzle			Danfoss 0.55-60AS	Delavan 0.65-60W		
Pump pressure			165	175		
Combustion air adjustment (turbulator/damper)			0 / 1.5	2 / 1.0		
GENERAL INFORMATION						
Overall dimensions (width x depth x height)	20" x 20" x 51"				24" x 24" x 59 1/2"	
Flue pipe diameter	6"				6"	
Tank capacity	121 L / 32 US gal				190 L / 50 US gal	
Shipping weight	77 kg / 171 lbs				120 kg / 264 lbs	
Maximum operating pressure 150PSI						

Figure 1 : Electrical wiring, Beckett burner

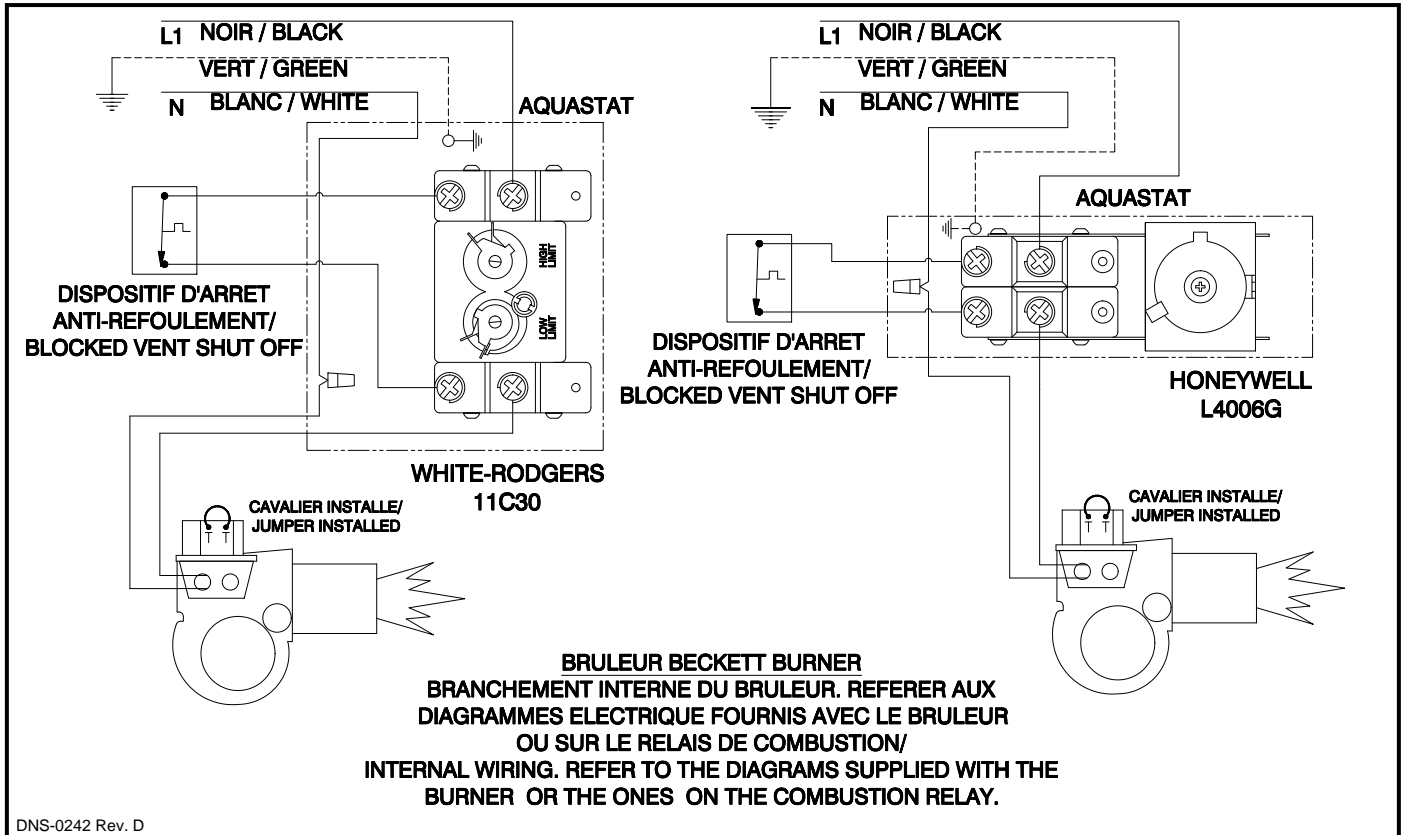
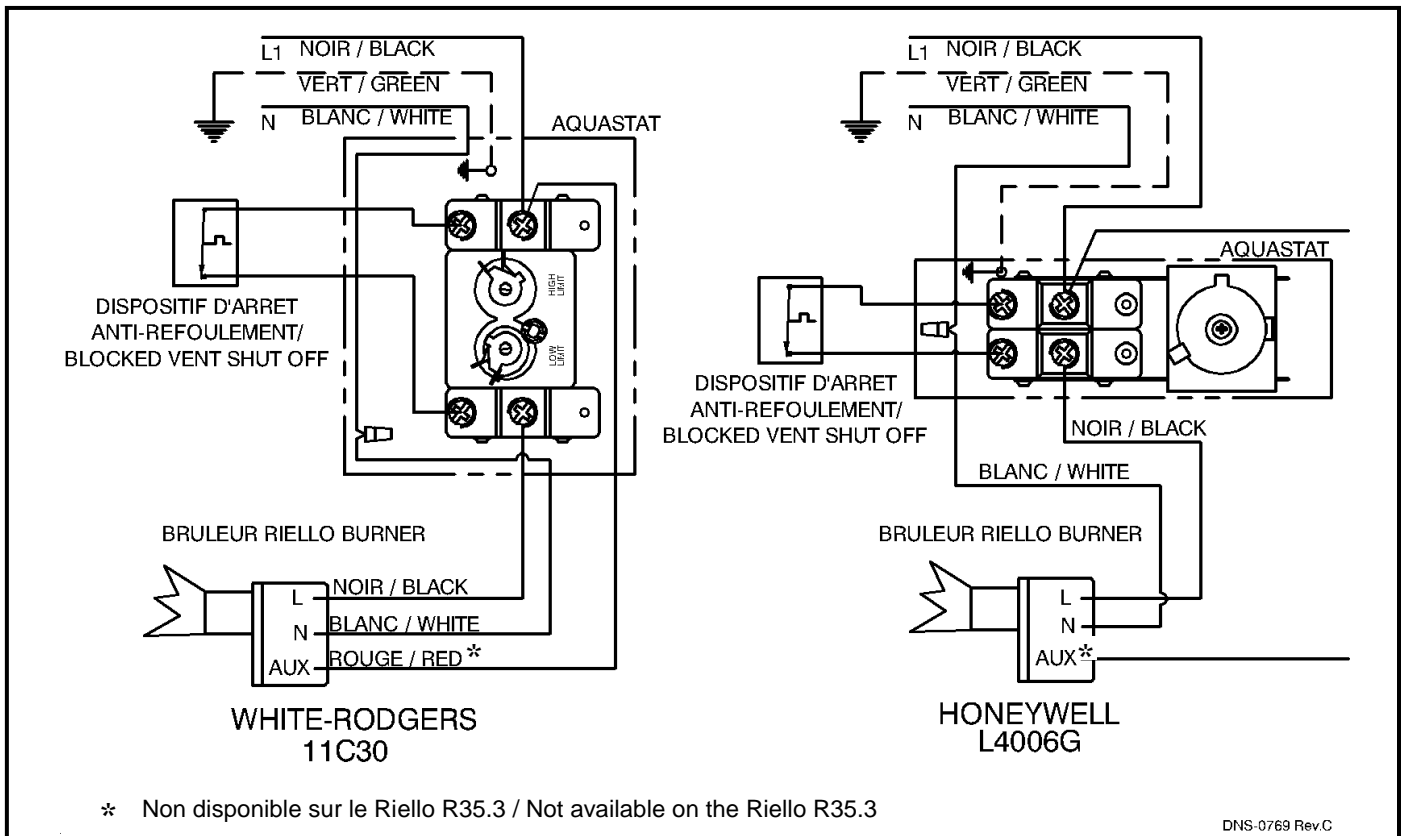
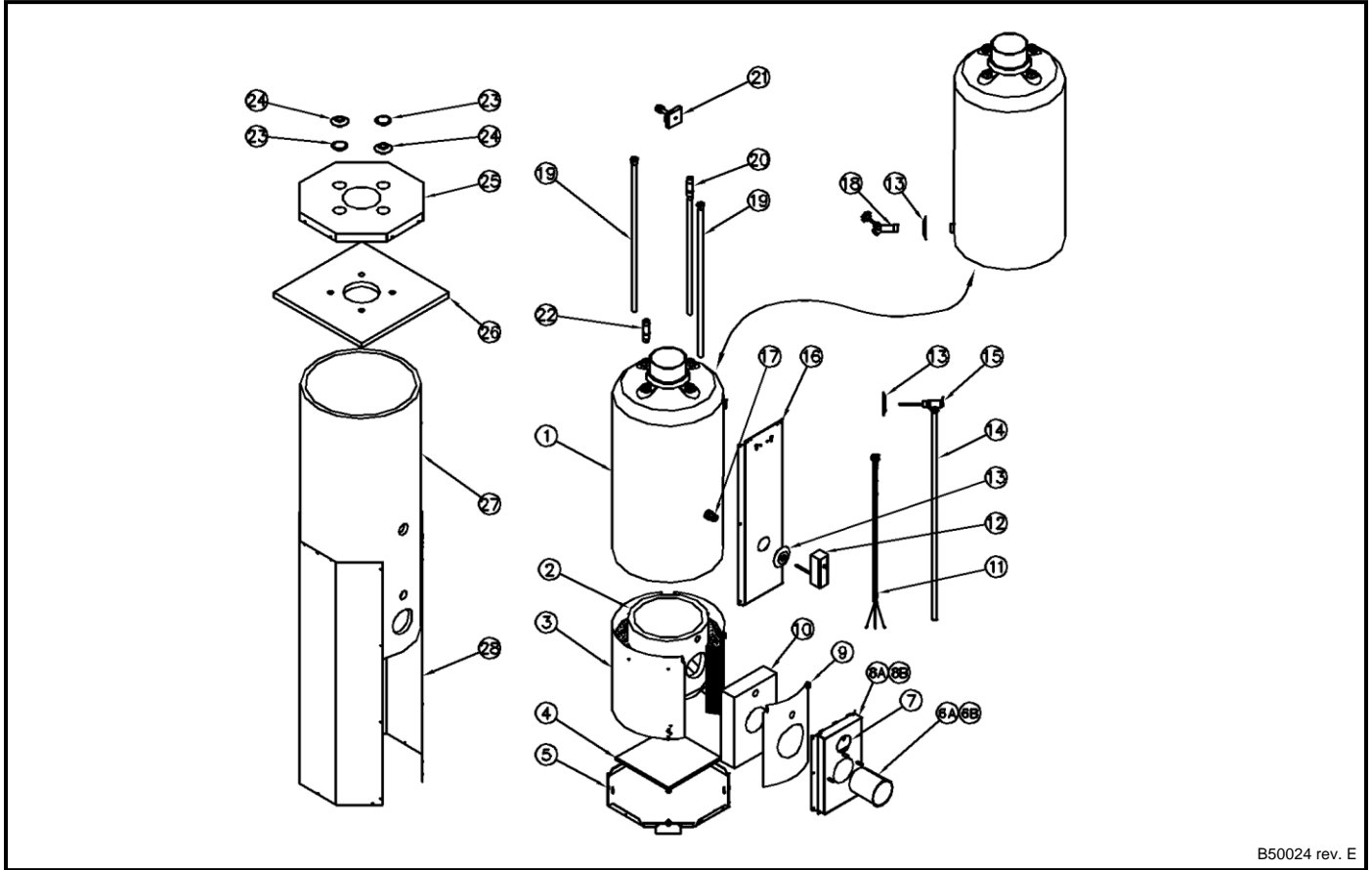

Figure 2 : Electrical wiring, Riello burners



7.0 REPLACEMENT PARTS

Figure 3 : Parts List, Model 32



B50024 rev. E

Table 3: Parts List, Model 32

ITEM	PART #	DESCRIPTION	COMMENTS
1	B10373-04	TANK, REPLACEMENT	
2	B10093	REFRACTORY HEAT CHAMBER	
3	B10361	HEAT CHAMBER AND INSULATION ASSEMBLY (includes items 2, 3, 4, 5, 9 & 10)	
4	B00619-53	INSULATION	
5	B10072	FLOOR	
6A	B10083-01	INSERTION COLLAR	Insertion 5 5/8"
6B	B10083-02	INSERTION COLLAR	Insertion 4 5/8" to 4 3/4"
7	B00403	OBSERVATION DOOR	
8A	B10421	PANEL ASSEMBLY, BOTTOMFRONT	Insertion 5 5/8"
8B	B10421-01	PANEL ASSEMBLY, BOTTOMFRONT	Insertion 4 5/8" to 4 3/4"
9	B10074	COLLAR, FRONT INTERIOR	
10	B10306	COLLAR INSULATION, FRONT INTERIOR	
11	B03114-01	BVSO ELECTRICAL KIT	
12	R02G003	DOUBLE AQUASTAT HONEYWELL L4006G1022	
13	G14G007	GASKET, 3-3/4"OD 1" ID LDPE WHITE	
14	G99Z019	OVERFLOW TUBE, 3/4"NPT x 42"	
15	G11F024	RELIEF VALVE, 150# 3/4x3/4 W 100XL-4	
16	B10359-01	PANEL ASSEMBLY, TOP FRONT	
17	R02J008	WELL, 3/4"NPT	
18	G11Z025	DRAIN VALVE, 3/4" x 3"	
19	G99Z003	MAGNESIUM ANODE 3/4"NPT .750" x 30"	
20	G99Z020	DIP TUBE 3/4"NPT x 27"	
21	Z06G001	BLOCKED VENT SHUT-OFF BVSO-225-A	
22	G99Z004	NIPPLE WITH PLACTIC SLEEVE 3/4" x 4" ZINC	
23	G14F006	FLUSH PLUG 2" BLACK PLASTIC	
24	G14G001	GASKET, 2-7/8" OD 1" ID LDPE WHITE	
25	B10362	TOP PANEL ASSEMBLY	
26	B10079	INSULATION, TOP PANEL	
27	B10078	CASING INSULATION	
28	B10360-01	CASING ASSEMBLY	

B50024 rev. F

Figure 4 : Parts List, Model 50

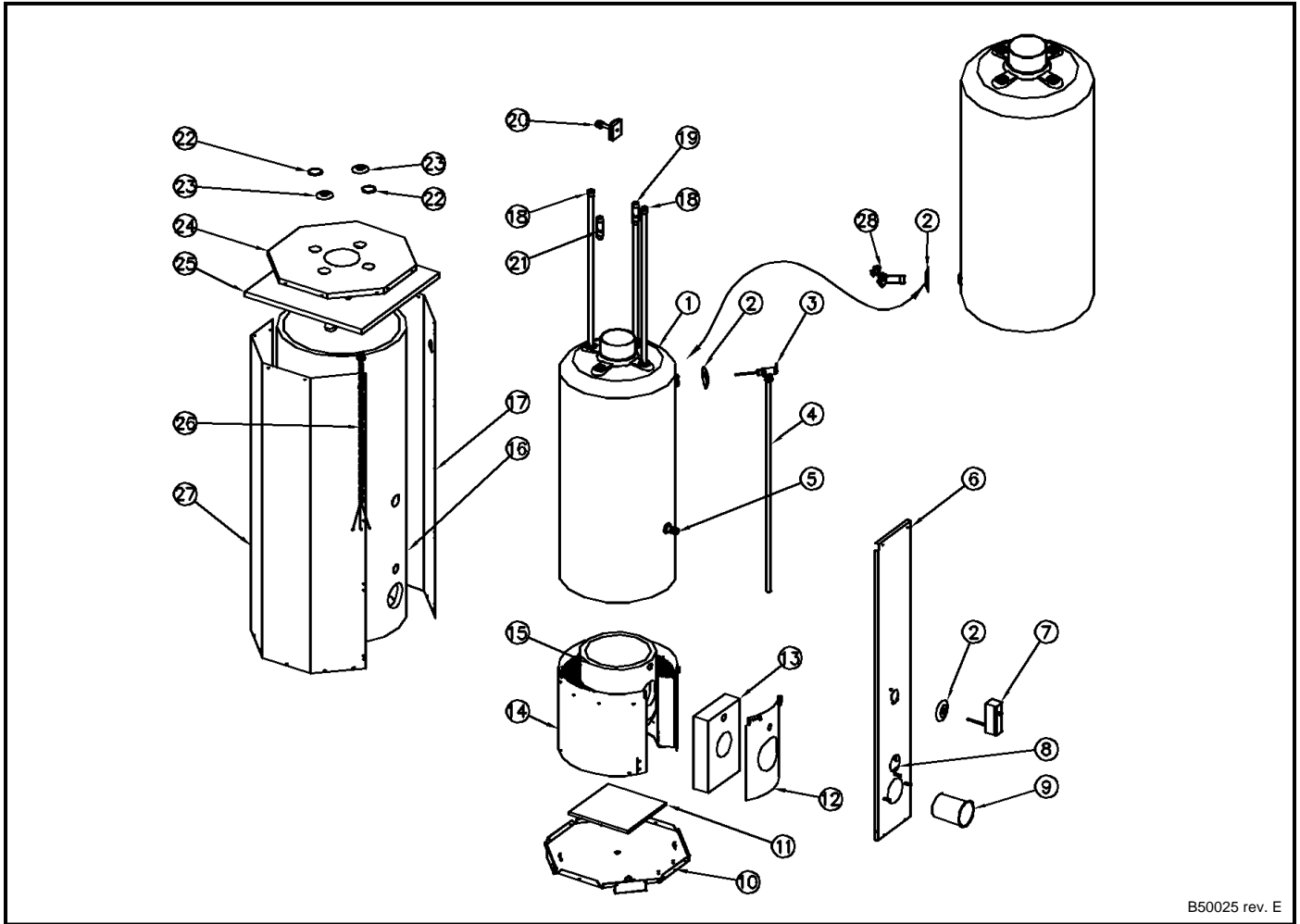

B50025 rev. E

Table 4 : Parts List, Model 50

ITEM	PART #	DESCRIPTION	COMMENTS
1	B10373-05	TANK, REPLACEMENT	
2	G14G007	GASKET, 3-3/4"OD 1" ID LDPE WHITE	
3	G11F002	TEMPERATURE/PRESSURE VALVE 150 PSI 3/4"	
4	G99Z019	OVERFLOW TUBE, 3/4"NPT x 42"	
5	B10322	WELL.	
6	B10365-04	FRONT PANEL ASSEMBLY	
7	R02G003	DOUBLE AQUASTAT	
8	B00403	OBSERVATION DOOR	
9	B10083	INSERTION COLLAR	
10	B10291	FLOOR ASSEMBLY	
11	B00619-53	INSULATION	
12	B10074	COLLAR, FRONT INTERIOR	
13	B10306	COLLAR INSULATION, FRONT INTERIOR	
14	B10368	HEAT CHAMBER AND INSULATION ASSEMBLY (includes items 0, 11, 12, 13, 14 & 15)	
15	B10093	REFRACTORY HEAT CHAMBER	
16	B10424	CASING INSULATION	
17	B10366	CASING ASSEMBLY, RIGHT SIDE	
18	G99Z003	MAGNESIUM ANODE 3/4"NPT .750" x 30"	
19	G99Z022	DIP TUBE 3/4"NPT x 29"	
20	Z06G001	BLOCKED VENT SHUT-OFF BVSO-225	
21	G99Z004	NIPPLE WITH PLACTIC SLEEVE 3/4" x 4" ZINC	
22	G14F006	FLUSH PLUG 2" BLACK PLASTIC	
23	G14G001	GASKET, 2-7/8" OD 1" ID LDPE WHITE	
24	B10369-01	TOP PANEL ASSEMBLY	
25	B10299	INSULATION, TOP PANEL	
26	B03114-02	ELECTRICAL KIT BVSO	
27	B10294	CASING, LEFT SIDE	
28	G11Z025	DRAIN VALVE, 3/4" x 3"	