

INSTALLATION INSTRUCTIONS AND HOMEOWNER'S MANUAL



HYDRA III

ELECTRIC BOILER
ELECTRONIC CONTROL



Models:

HYDRAT15-E2401M
HYDRAT18-E2401M
HYDRAT20-E2401M
HYDRAT24-E2401M
HYDRAT27-E2401M
HYDRAT29-E2401M



INSTALLER / SERVICE TECHNICIAN:

**USE THE INFORMATION IN THIS MANUAL FOR THE
INSTALLATION AND SERVICING AND KEEP THE
DOCUMENT NEAR THE UNIT FOR FUTURE REFERENCE.**

HOMEOWNER:

**PLEASE KEEP THIS MANUAL NEAR THE FURNACE FOR
FUTURE REFERENCE.**

Caution:

**Do not tamper with the unit or
its controls. Call a qualified
service technician.**

Manufactured by:

**Dettson Industries Inc.
Sherbrooke, Qc, Canada
www.dettson.com**

Table of Contents

1 SAFETY	3
1.1 DANGER, WARNING AND CAUTION . . .	3
1.2 IMPORTANT INFORMATION	3
1.3 DANGER OF FREEZING	3
2 INSTALLATION	4
2.1 HEATING WITH HOT WATER	4
2.2 DELIVERY	4
2.3 POSITIONING AND CLEARANCES	4
2.4 DISTRIBUTION SYSTEM	6
2.5 BOILER INSTALLATION	7
2.6 ELECTRIC POWER SUPPLY	7
3 OPERATION	8
3.1 ADJUSTMENTS AND START-UP	8
3.2 OPERATING PRINCIPLE	8
3.3 MECHANICAL HIGH LIMIT	8
3.4 ELECTRONIC CONTROL	9
4 MAINTENANCE	13
5 INFORMATION	13
6 TECHNICAL DATA	14

List of Figures

Figure 1: Mounting Configurations	5
Figure 2: Menu Navigation	11
Figure 3: Modulation as Function of the Outdoor Temperature	12
Figure 4: Boiler Components and Dimensions	15
Figure 5: Typical Diagram of a Single Zone Installation	16
Figure 6: Multi-zone Diagram with more than one Circulator	16
Figure 7: Multi-zone Diagram with Motorized Valves	17
Figure 8: Dual-Energy Installation	17
Figure 9: Electrical Diagram	18
Figure 10: Electrical Pannel	19
Figure 11: Parts List	20

List of Tables

Table 1: Minimum Clearances to Combustible Material	5
Table 2: Circulating Pump Flow Rates	6
Table 3: Alarm Description	10
Table 4: Technical Specifications	14
Table 5: Parts List	21
Table 6: List of Wires	21
Table 7: Resistance Table of Temperature Sensors 10k Ω	22

1 SAFETY

1.1 DANGER, WARNING AND CAUTION

The words **DANGER**, **WARNING** and **CAUTION** are used to identify the levels of seriousness of certain hazards. It is important that you understand their meaning. You will notice these words in the manual as follows:



DANGER

Immediate hazards which WILL result in death or serious bodily and/or material damage.



WARNING

Hazards or unsafe practices which CAN result in death or serious bodily and /or material damage.

CAUTION

Hazards or unsafe practices which CAN result in minor bodily and /or material damage.

1.2 IMPORTANT INFORMATION



WARNING

Non-observance of the safety regulations outlined in this manual will potentially lead to consequences resulting in death, serious bodily injury and/or property damage.



WARNING

Installation and repairs performed by unqualified persons can result in hazards to them and to others. Installations must conform to local codes or, in the absence of such codes, to codes of the country having jurisdiction.

The information contained in this manual is intended for use by a qualified technician, familiar with safety procedures and who is equipped with the proper tools and test instruments.

Failure to carefully read and follow all instructions in this manual can result in death, bodily injury and/or property damage.

- (a) It is the homeowner's responsibility to engage a qualified technician for the installation and subsequent servicing of this boiler;
- (b) Do not store any flammable substances, such as paper or carton, near the boiler;
- (c) Ask the technician installing your boiler to show and explain to you the main disconnect switch or circuit breaker;
- (d) Before calling for service, be sure to have the information of section 5 of your manual close by in order to be able to provide the contractor with the required information, such as the model and serial numbers of the boiler.

IMPORTANT : All local and national code requirements governing the installation of central electric heating equipment and wiring **MUST** be followed. Some of the codes that may apply are:

- **CSA B214-01** Installation Code Hydronic Heating Systems
- **CSA C22.1** ou **CSA C22.10** Canadian Electrical Code

Only the latest issues of these codes shall be used, and are available from:

The Canadian Standards Association
178 Rexdale Blvd.
Rexdale, Ontario M9W 1R3
www.shop.csa.ca

1.3 DANGER OF FREEZING

CAUTION

If your boiler is shut down during the cold weather season, water pipes may freeze, burst and cause serious water damage. Turn off the water supply and bleed the pipes.

If the heater is left unattended during the cold weather season, take the following precautions:

- a) Close the main water valve in the house and purge the pipes if possible. Open all the faucets in the house;
- b) Ask someone to frequently check the house during the cold weather season to make sure that there is sufficient heat to prevent the pipes from freezing. Tell this person to call an emergency number if required.

2 INSTALLATION

WARNING

The installation of this unit must be performed by a qualified technician and it must conform to the standards and regulations in force as well as the Canadian Installation Code for Hydronic Heating Systems CSA B214-01.

2.1 HEATING WITH HOT WATER

Your HYDRA III electric boiler was carefully assembled and checked in our plant, so that it will deliver warmth and comfort to your home for many years to come.

This manual is intended to provide the necessary information for the installation of the unit, how it functions and explains security measures which are particular to this type of equipment.

It is essential that the persons installing, operating or adjusting the boiler carefully read this manual, in order to completely understand and be familiar with the procedures to be followed.

Any questions relative to the operation, maintenance or guarantee should be directed to the company where the equipment was purchased.

Upon completion of the installation, this manual should be placed back into its original envelope and kept near the boiler for future reference.

2.2 DELIVERY

Upon delivery of the boiler, check the nameplate to be sure that you have received the model with the correct rating and proper voltage.

The following items are supplied with the unit:

- A pressure relief valve, adjusted to 30 psi;
- A drain valve;
- An exterior probe for modulation;
- Two 1" X 3/4" (15-20 kW) or 1 1/4" X 3/4" (24-29 kW) reducers for drain valve and pressure relief valve.

2.3 POSITIONING AND CLEARANCES

The unit must be installed in an area that is dry, non-corrosive, without excessive dust, well ventilated and where the ambient temperature does not exceed 27°C (80°F).

The boiler can be installed using the included mounting brackets. First, unfold the four tabs on the back panel of the boiler. Position the top bracket and secure it to a wall. Place the boiler on the top bracket and then secure the bottom. Finally, use self-tapping screw to secure the tabs to the bracket. Ensure that the unit is well fixed on the wall utilizing the 2 mounting brackets.

The boiler can be installed in 6 possible configurations as shown in Figure 1. The arrows represent the direction of the water flow.

Ensure that it is installed level and that the clearances indicated in Table 1 are respected.

If the boiler is in an enclosure, provide a door or a removable panel in front to access the control panel. Ideally have a 24" clearance on the front for servicing.

Figure 1 – Mounting Configurations

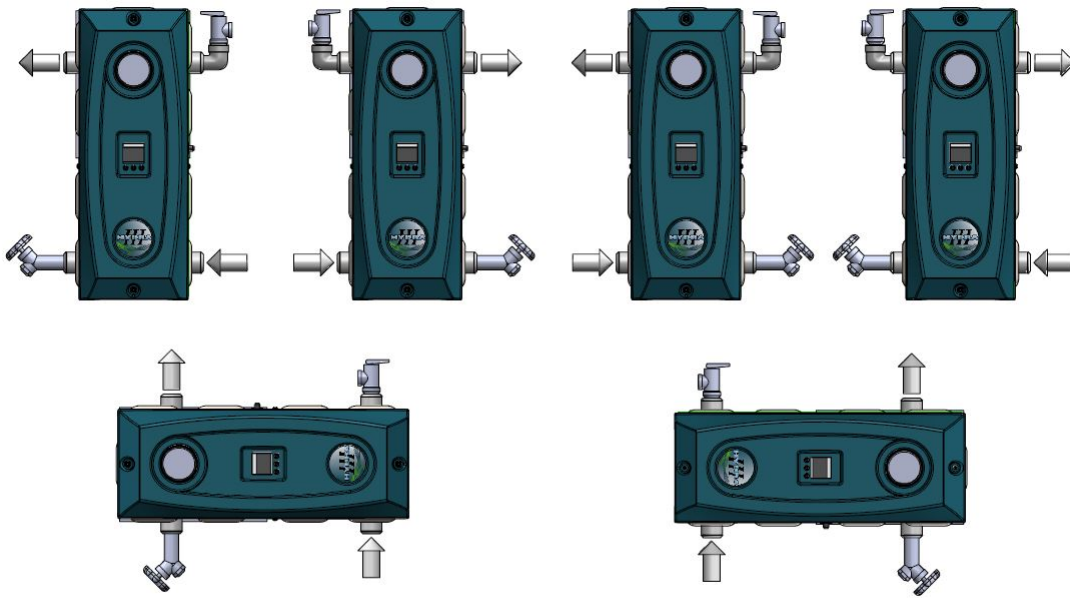

DNS1489D

Table 1 – Minimum Clearances to Combustible Material

Location	Clearance
Top (access to elements)	13 ¼" (34 cm)
Sides	4" (10 cm)
Bottom	0
Front	0
Back	0

Table 2 – Circulating Pump Flow Rates

Model	kW	Minimal flow	$\Delta T = 10^{\circ}F$	$\Delta T = 20^{\circ}F$
		USGPM (L/min)	USGPM (L/min)	USGPM (L/min)
HYDRAT15-E2401M	15	5.1 (19.3)	10.2 (38.7)	5.1 (19.3)
HYDRAT18-E2401M	18	6.1 (23.2)	12.3 (46.4)	6.1 (23.2)
HYDRAT20-E2401M	20	6.8 (25.8)	13.6 (51.6)	6.8 (25.8)
HYDRAT24-E2401M	24	8.2 (30.9)	16.3 (61.9)	8.2 (30.9)
HYDRAT27-E2401M	27	9.2 (34.8)	18.4 (69.6)	9.2 (34.8)
HYDRAT29-E2401M	29	9.9 (37.4)	19.7 (74.7)	9.9 (37.4)

2.4 DISTRIBUTION SYSTEM

The proper functioning of your heating system is directly related to the quality of the plumbing installation. Therefore, the entire installation must be performed by qualified technicians.

See Figure 4 for the various boiler components.

The heating system should be set-up to operate at a pressure around 12 psi. The maximum operating pressure is 28 psi, but such a high pressure is abnormal and requires inspection from a service technician. The operating temperature may range from 5°C to 88°C (41°F to 190°F).

All installations must include the following items:

- 1 pressure regulator, adjusted to 12 psi, must be installed between the boiler and the main water supply in the building;
- 1 expansion tank, pre-pressurized to 12 psi and of appropriate size;
- 1 or more circulating pumps of appropriate capacity.
- 1 or more air purge valves;

WARNING

BURN HAZARD

To avoid water damage and/or scalding due to relief valve operation, a discharge line must be connected to the valve outlet and run to a drainage area. The discharge line shall be installed in such a way that it will allow for the complete drainage of the valve and the discharge line.

2.4.1 Circulating Pump

The circulating pump must be selected according to the heating distribution system and the heating capacity of the boiler. Table 2 shows necessary water flows according to various temperature rises. For example, a system using baseboard heaters will usually require a temperature rise of 20°F, whereas a radiant floor system will use a rise around 10°F.

2.4.2 Freeze protection (when required)

WARNING

Only propylene glycol may be used in this hydronic heating system to prevent freezing. It is recommended to add a maximum of 50% of propylene glycol mixture to ensure proper operation.

Do not use automotive anti-freeze, ethylene glycol or any undiluted anti-freeze.

If the above recommendations are not followed, severe personal injury, death or substantial property damage can result.

2.5 BOILER INSTALLATION

At the time of installation, the following steps should be followed. Refer to Figure 5, Figure 6, Figure 7 and Figure 8.

1. Choose an appropriate location. Mount the boiler securely on the wall with the help of the mounting plate. Ensure that it is level and that the minimum clearances are observed;
2. Install the drain valve and the safety valve according to the mounting configuration as shown in Figure 1;
3. Install the water supply and return piping with the 1" NPT (15 to 20 kW) or 1¼" NPT (24 to 29 kW) fitting;
4. The heating supply line must include:
 - (a) 1 circulator along with 2 maintenance valves;
 - (b) 1 automatic pressure reducing valve adjusted to 12 psi, with a shut-off valve on the return water line;
 - (c) 1 expansion tank;
 - (d) 1 automatic vent.
5. In order to ensure satisfactory water flow, the friction in the piping system must not exceed the capacity of the circulator;
6. After having completed all piping connections, run water through the system and purge the air. An automatic vent should be in operation.

Note: Remove the top cover and check to see if the elements are watertight.

2.6 ELECTRIC POWER SUPPLY

All electrical wiring must conform to the standards and regulations in force and to the Canadian Electrical Code CSA C22.1.

Electric power to the boiler must come from a 120/240V 60 Hz or 208V 60 Hz, single phase, grounded circuit, protected by an appropriately sized breaker, based on the total rating of the boiler. Refer to the boiler nameplate and the technical specifications in this manual to select the proper breaker and wire size. Normally, **3 conductors** are required. If the circulating pump has an external power source, and if no other accessory requires the 120V output from the boiler, only **2 conductors** can be used. Use cable rated at 60°C or higher.

When using 208V, change the connector's position at the primary of the transformer.

Make sure to turn off all electrical circuits when working in the appliance.

WARNING

FIRE HAZARD

The conductor sizing must conform to the last edition of the local or national codes.

Power supply to the unit can be made using copper or aluminum wires. The wire size must be decided in accordance to unit power consumption, the over current protection type and capacity, the wire type and length, and the environment where the unit is installed. If an aluminum wire is used, other precautions (such as the use of a DE-OX inhibitor) must be taken to insure the conformity of the installation. In all cases, all the factors affecting the wire gauge must be considered and the installation codes followed.

The exterior of the unit must have an uninterrupted ground to minimize the risk of bodily harm. A ground terminal is supplied with the control box for that purpose.

It is highly recommended to have a surge protector installed on the boiler.

In the event that wires inside the unit require replacement, these must be as same type as originals (copper wiring only).

2.6.1 Connecting the Circulation Pump

Connect the circulating pump on 120V connection points identified N for neutral and P for controlled 120V output in the control panel. The electronic control is designed to operate the circulator on thermostat demand, with a heat purge delay at the end of heating cycle or continuous flow. Refer to the electronic control section to learn how to configure this function.

2.6.2 Single and Multiple Zone Connections

Single Heating Zone

Connect the low voltage thermostat to R(T)-W(T) terminals located inside the control panel. See Figure 5.

Multiple Heating Zone

Connect the contacts of the motorized valves or pump controls to R(T)-W(T) terminals inside the control panel. See Figure 6 and Figure 7.

2.6.3 Outdoor Sensor Connection

Mount the sensor on an outside wall, protected from direct sunlight, so that it will accurately measure the outside temperature. Install 2 #20 wires between the outdoor sensor and the terminals identified as EXT1 and EXT2 inside the control panel of the boiler. This sensor will allow the boiler to modulate its set point according to the outdoor temperature, as per figure 3.

3 OPERATION

3.1 ADJUSTMENTS AND START-UP

CAUTION

The boiler must be filled with water and all air purged from the system, before turning on the power. If the power is turned on before the boiler is filled with water, the elements will become seriously damaged. Warranty will be void.

1. Turn the power on.
2. Adjust the set point of the boiler on the electronic control. See the electronic control section for adjustments.
3. Set the thermostat at 30°C (85°F). The circulator should start as well as the electrical elements in sequence with a 15 seconds delay, if CMD displays 100% (see section 3.4.1).
4. The circulator stays on for as long as there is a call for heat except if differently configured on the electronic control, as explained in section 3.4.2.

3.2 OPERATING PRINCIPLE

The control activates the electrical elements. There is a delay before turning on (2 minutes max.) or off (30 seconds max.) each individual element. When the set point is reached, the number of activated elements will be adjusted in order to maintain the water temperature, while minimizing the on/off cycling. This allows for a better longevity of all components and energy savings.

3.3 MECHANICAL HIGH LIMIT

3.3.1 Mechanical High Limit Control

The mechanical limit aquastat (big black knob) must be set 30°F above the set point temperature on the

electronic control.

3.3.2 Manual Reset High Limit Control

Turn the power to the unit off before resetting the high limit. The manual reset high limit is set at 100°C (212°F). To reset this protection, the boiler needs to cool down. Then the black button shall be pressed using a pen or screwdriver. Refer to figure 4 to locate the high limit thermodisc.

3.4 ELECTRONIC CONTROL

Figure 2 shows how to navigate the various menus.

3.4.1 Display

```
PUMP : OFF
SET P : 149.0 °F
TARGET : 149.0 °F
T° IN : 62.5 °F
T° OUT : UNUSED
Cmd : 0%
```

PUMP: State of the pump.

SET P: Temperature set point.

TARGET: Target temperature. This will vary according to the outdoor temperature (Figure 3).

T° IN: Temperature inside the device.

T° OUT: Outdoor temperature.

CMD: Percentage of power sent to the elements.

From this screen and by pressing the directional buttons, the user can switch from the various menus available. The center button allows to switch the view between CMD and individual elements.

3.4.2 Installer

```
INSTALLER
PASSWORD
****
```

The installer menu's goal is to make the technician's work easier. This menu is protected by a password that can be found on the electrical schematic affixed to the plastic case of the HYDRA III. The password consists of a combination of characters entered with the three buttons of the Hydra (left, center, right then center).

```
INSTALLER
PASSWORD
WRONG ANSWER
```

```
INSTALLER
PASSWORD
CORRECT
```



Once the password is confirmed, press the center button to enter the menu. The homeowner shouldn't try to gain access to this menu as it is used to program the behaviour of the appliance.

```
INSTALLER
-> TYPE : MAN.
PUMP : OFF
SET P : 149.0 °F
T° OUT : UNUSED
↓
```

TYPE: Gives a pre-set value to the temperature set point.

Mass, Baseboard, Light and Cast Iron are pre-set values for determining temperature set point. Manual allows the installer to manually choose the set point.

PUMP: Choose the way to drive the pump. OFF means the pump will activate only when there is a demand from the thermostat. ON means that the pump will always be active. Time values indicate that the pump will stay on for this time before deactivating following the end of a heating demand from the thermostat.

SET P: Indicates the temperature the device will try to reach upon the reception of a signal from the thermostat, unless the outdoor sensor modifies it.

T° OUT: Allows the device to know if an outdoor sensor is being used.

```
INSTALLER
↑
-> ENERGY : ELEC
OFFSET : NO
TESTS
BACK
```

ENERGY: Sets the way the machine will manage its energy.

DUAL tells the device that upon receiving a signal from the electrical network or based on outdoor temperature, it will transfer the heating demand exclusively to an auxiliary boiler (this is mostly the case when the energy provider is Hydro-Quebec);

AUX means the Hydra will be completely bypassed and an auxiliary boiler (e.g. oil boiler) which will be used to produce heat instead;

ELEC means there won't be a dual energy system and thus the HYDRA III will be the only source of heat.

OFFSET: Set the allowed temperature offset (deadband) from the set point. This option can help when the cycling of the elements is too fast, by slowing the heat resumption when the set point is reached.

TESTS: Access to the Tests tab appearing on the controller's screen is protected by a password. Under no circumstances should a user try to access it. This function is used at the Dettson factory to test the HYDRA III before it is shipped to a distributor.

BACK: Allows going back to the previous menu. This has the same functionality across all menus.

3.4.3 Configuration

The configuration menu allows the user to adjust some settings.

```
CONFIGURATION
HYDRA III 20KW
-> UNITS T : °F
LANGUAGE : EN
POWER : HIGH
BACK
```

UNITS T: Units for temperature (Fahrenheit or Celsius degrees).

LANGUAGE: Language of displayed text (English or French).

POWER: Lowers the power of the device. Choosing LOW will limit the command at 50% of the maximum capacity.

3.4.4 Alarm

Some events may alter the functionality of the device in an undesired manner. These events trigger alarms in the system that remains stored in the device's memory. Reasons for alarms are: troubles with the internal or the external heat sensor, problems with elements and overheating (Table 3).

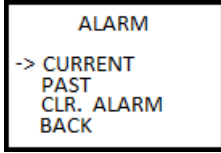

CURRENT: Shows alarms currently afflicting the device.

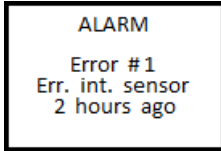

PAST: Shows a history of alarms triggered by the device. This allows to revisit the previous 25 alarm messages with an approximated time span since they happened.

CLR ALARM: Clears the alarm history.

3.4.5 Boost Mode

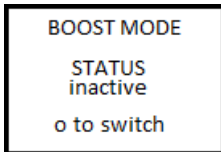

The boost mode menu allows the user to raise the boiler's temperature set point by 10 degrees Fahrenheit during 24 hours. Press the central button while in this menu to activate or deactivate this measure.

3.4.6 Dual Energy

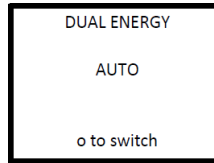

This menu is available when the dual energy setting is set in the installer menu. This allows to manually set the desired energy source.

As shown on the screen, pressing the central button will change the energy source. The choices are AUTO (automatic switching between the two modes, normal operation), ELEC or AUX (auxiliary heat).

3.4.7 Consumption

The consumption menu shows an approximated value of the power consumed by the boiler since it's last reset.

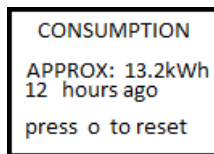

Consumption is written in kilowatt hour and time since last reset is given in hours or in days.

As shown on the screen, pressing the central button will reset the time and power consumed.

Table 3 – Alarm Description

Alarm	Description	Possible causes
T in	The boiler temperature sensor returns a temperature that is not within standard values	Misconnected sensor T in and T ext inverted Damaged wire Defective sensor (see table 7)
T out	The outdoor temperature sensor returns a temperature that is not within standard values	Misconnected sensor T in and T ext inverted Damaged wire Defective sensor (see table 7)
Overheat	The control is experiencing an increase in temperature when it does not send command to elements	The high limit aquastat is not set properly (see section 3.3.1) External heat source active in dual energy systems Defective relay or element
Element	The temperature in the boiler does not increase at a standard rate	An element is broken The load is more important than usual (large house, concrete floor, beginning of season) Not all elements are heating (Check the current drawn by the unit against the one on the rating plate)

Figure 2 – Menu Navigation

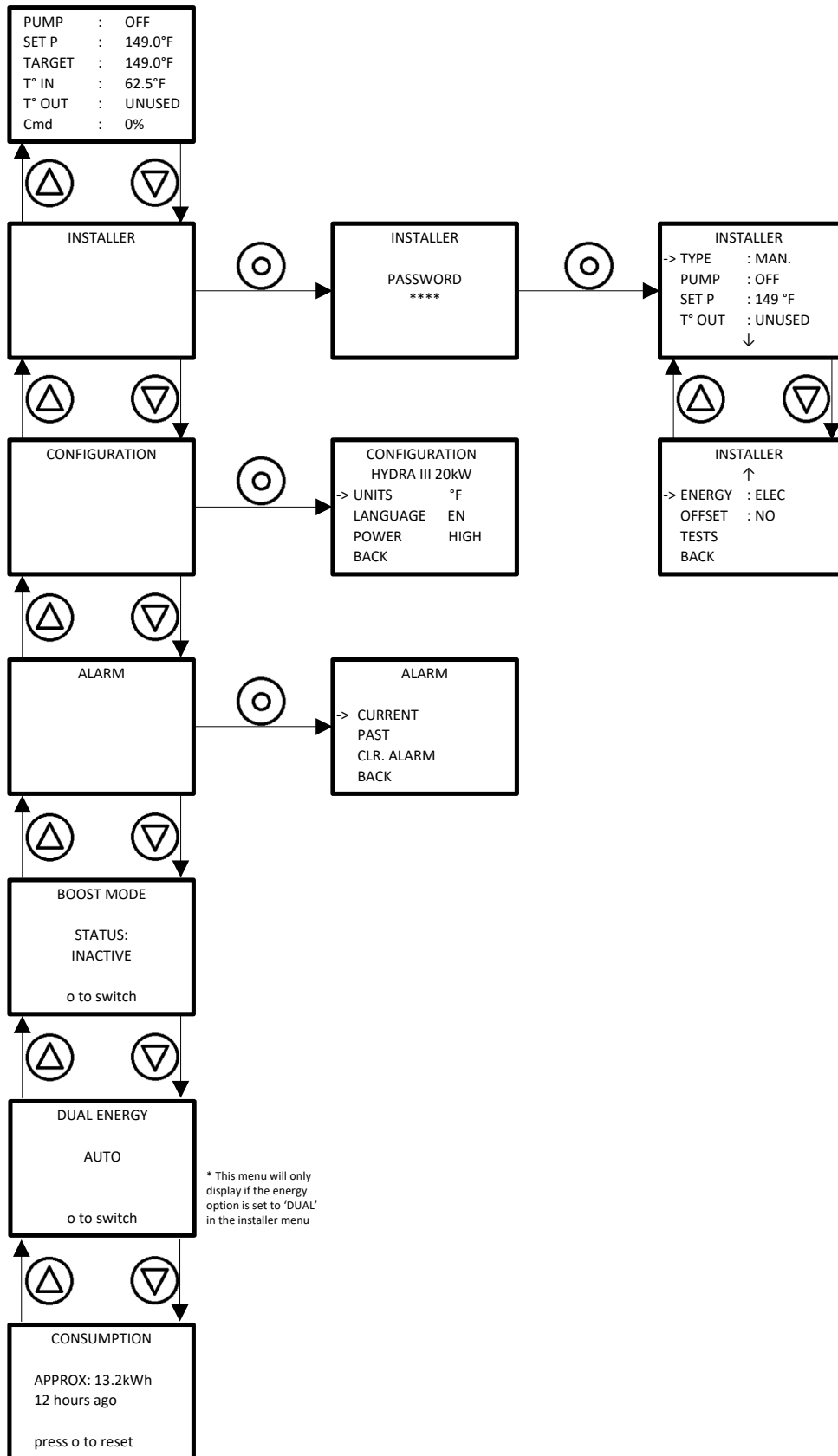
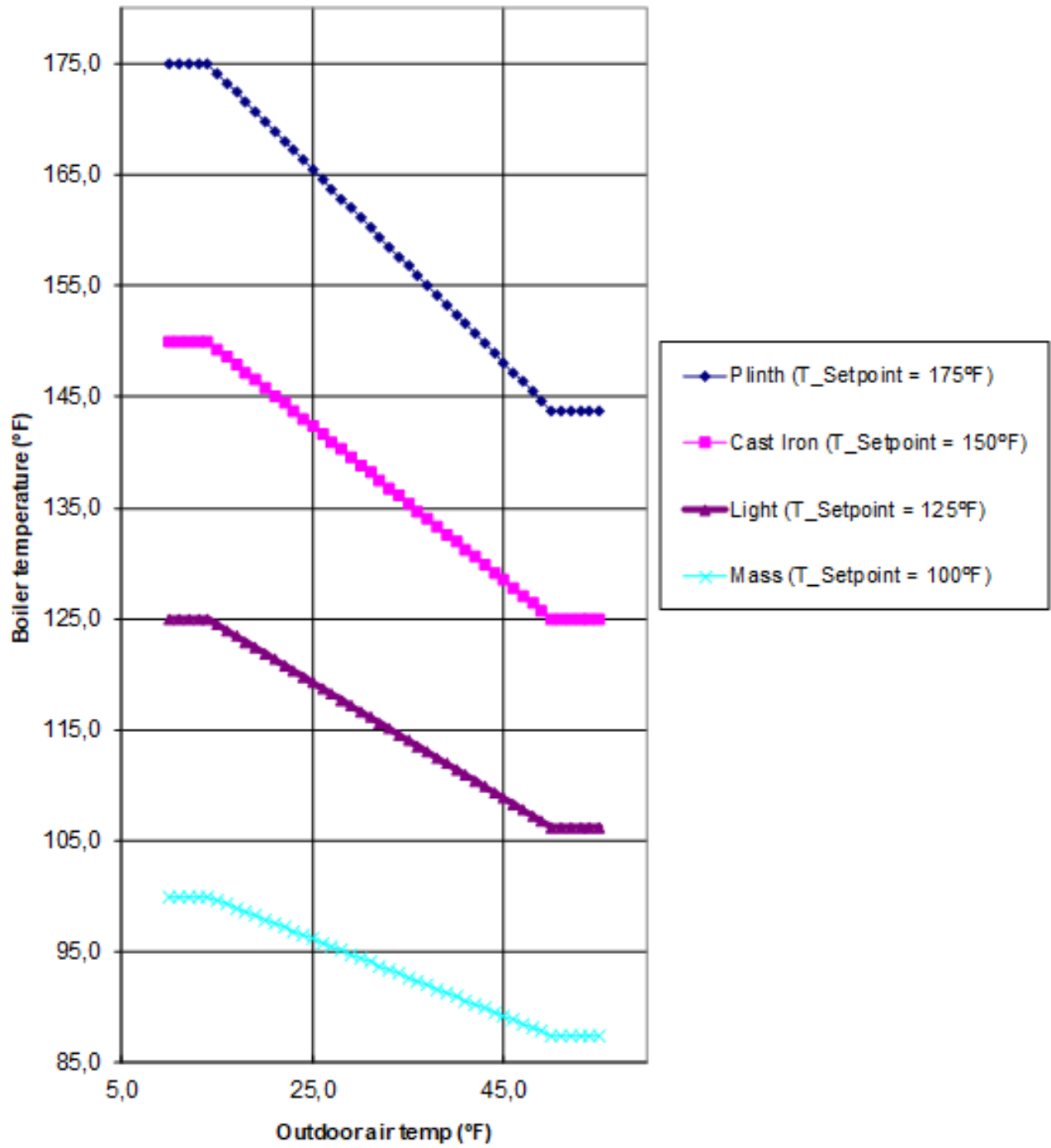

Figure 3 – Modulation as Function of the Outdoor Temperature



4 MAINTENANCE

The property owner has the following responsibilities:

1. To maintain the area around the boiler clean at all times and free from combustible and highly flammable material;
2. To ensure that the ambient air at the boiler is not excessively dusty or humid;
3. To have all water leaks repaired in the system as they arise.
4. To ensure that the ambient temperature in the area where the unit is installed does not exceed 27°C (80°F).

CAUTION

The boiler guarantee may be invalidated if: water leaks in the system are not repaired; the boiler is used as a source of domestic hot water; or a significant amount of new water or air is introduced into the system.

It is recommended that the boiler be purged annually, in order to eliminate sediment and sludge that may have accumulated at the bottom of the boiler and covered the heating elements.

Procedure:

1. Let the boiler cool down;
2. Close the maintenance valves, which are installed at the water inlet and outlet of the boiler. **N.B.: It is not recommended to drain the water from the heating pipe system;**
3. Hook-up a garden hose to the drain valve and place it close to a floor drain;
4. Open the purge valve until the water comes out clean and clear;
5. Close the valve.

It is recommended to perform a visual inspection of the boiler electrical compartment annually, during the heating season. The items to check are the water tightness of the elements, signs of overheating of the electrical components and the wiring. Corrective measures must be undertaken as required, as soon as possible.

Defective components should always be replaced with the Original Equipment Manufacturer's parts.

5 INFORMATION

Model: Serial number:

Installation date of the electric boiler:

Service telephone # - Day: Night:

Dealer name and address:

.....

.....

6 TECHNICAL DATA

Table 4 – Technical Specifications

Model number	Power (kW @240V / @208V)	Electric element #1 (kW)	Electric element #2 (kW)	Electric element #3 (kW)	Electric element #4 (kW)	Electric element #5 (kW)	Electric element #6 (kW)	Consumption (A @240V / @208V)	Suggested wire size (Cu / Al)	Suggested breaker size (A @240V)	Voltage - Frequency - Phase	Supply - Return	Dimensions (L x P x H) in	Shipping weight (lbs)
HYDRAT15-E2401M	15 / 11,3	5	5	5	-	-	-	63 / 54	6 / 4	80	240/208V - 60Hz - 1	1" NPT Female	8,2 x 12,4 x 21,4	65
HYDRAT18-E2401M	18 / 13,5	4	5	4	5	-	-	75 / 65	4 / 2	100				
HYDRAT20-E2401M	20 / 15,0	5	5	5	5	-	-	83 / 72	3 / 2	110				
HYDRAT24-E2401M	24 / 18,0	4	5	5	5	5	-	100 / 87	2 / 0	125		1 1/4" NPT Female	11,2 x 12,4 x 21,4	85
HYDRAT27-E2401M	27 / 20,3	4	4	5	4	5	5	113 / 98	1 / 00	150				
HYDRAT29-E2401M	29 / 21,8	4	5	5	5	5	5	121 / 105	1 / 00	175				
In all cases, refer to applicable local and national codes														

Figure 4 – Boiler Components and Dimensions

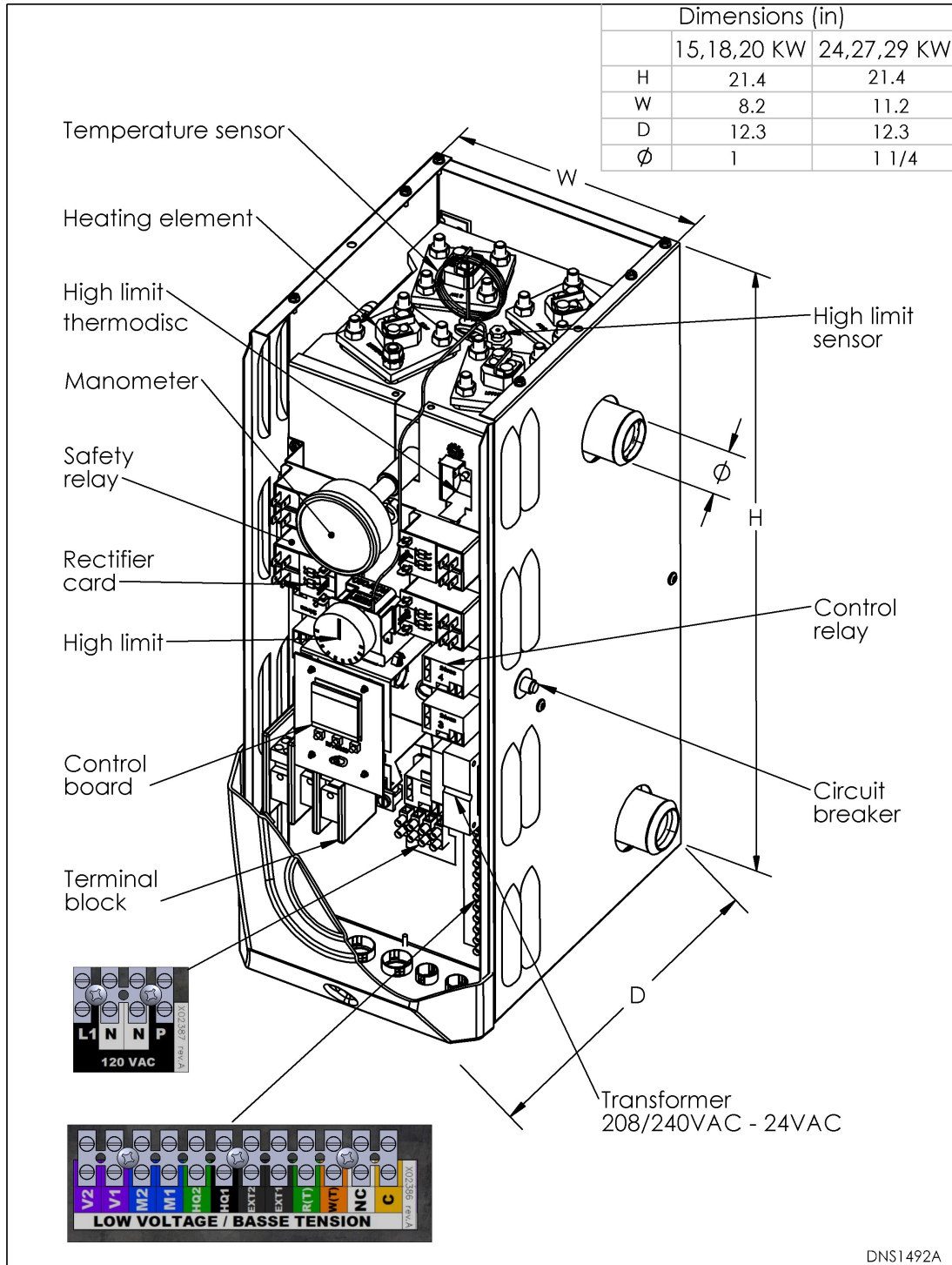

Figure 5 – Typical Diagram of a Single Zone Installation

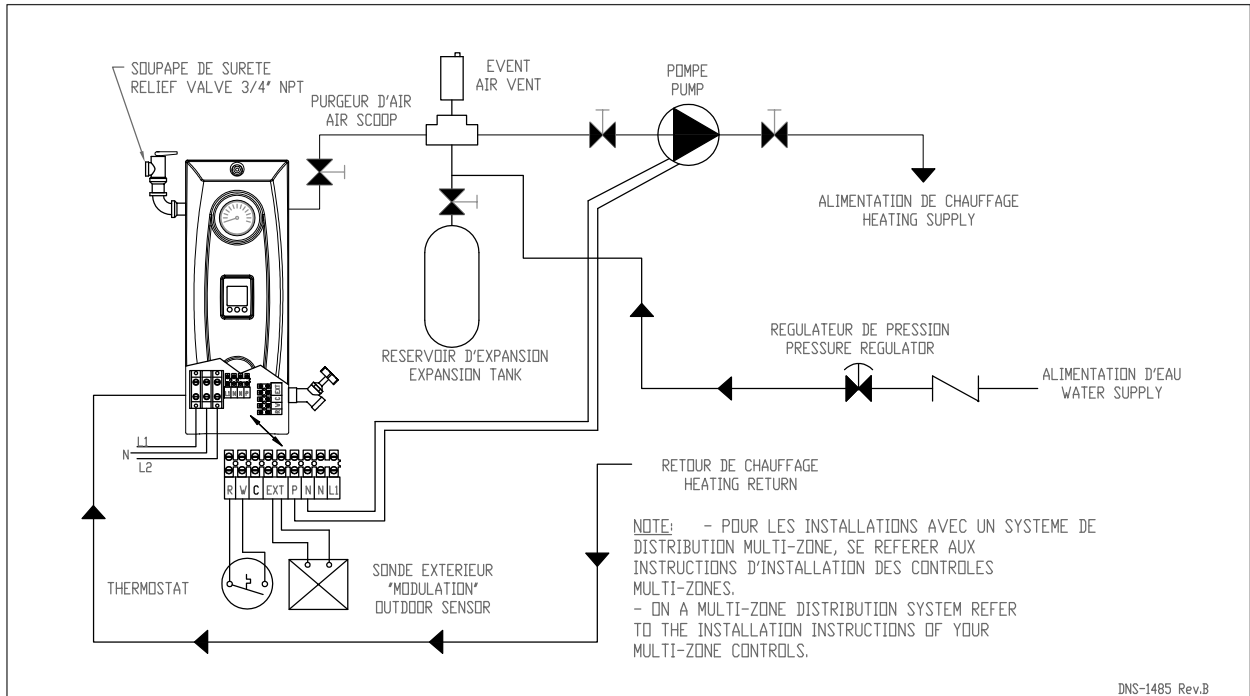

Figure 6 – Multi-zone Diagram with more than one Circulator

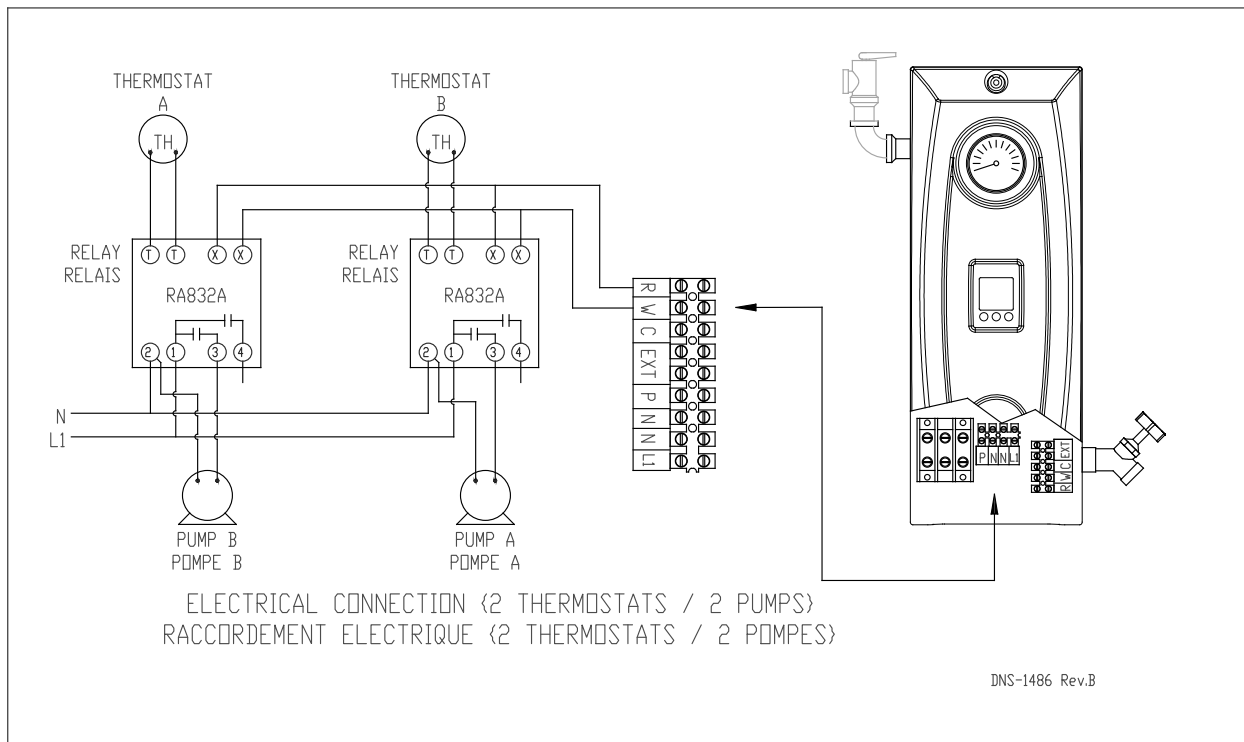

Figure 7 – Multi-zone Diagram with Motorized Valves

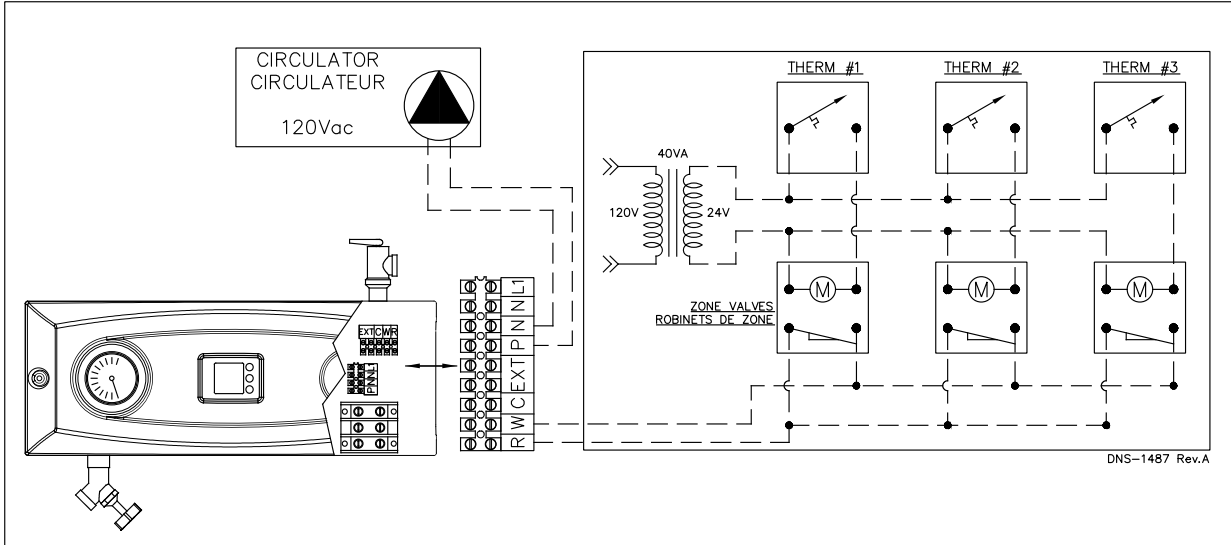

Figure 8 – Dual-Energy Installation

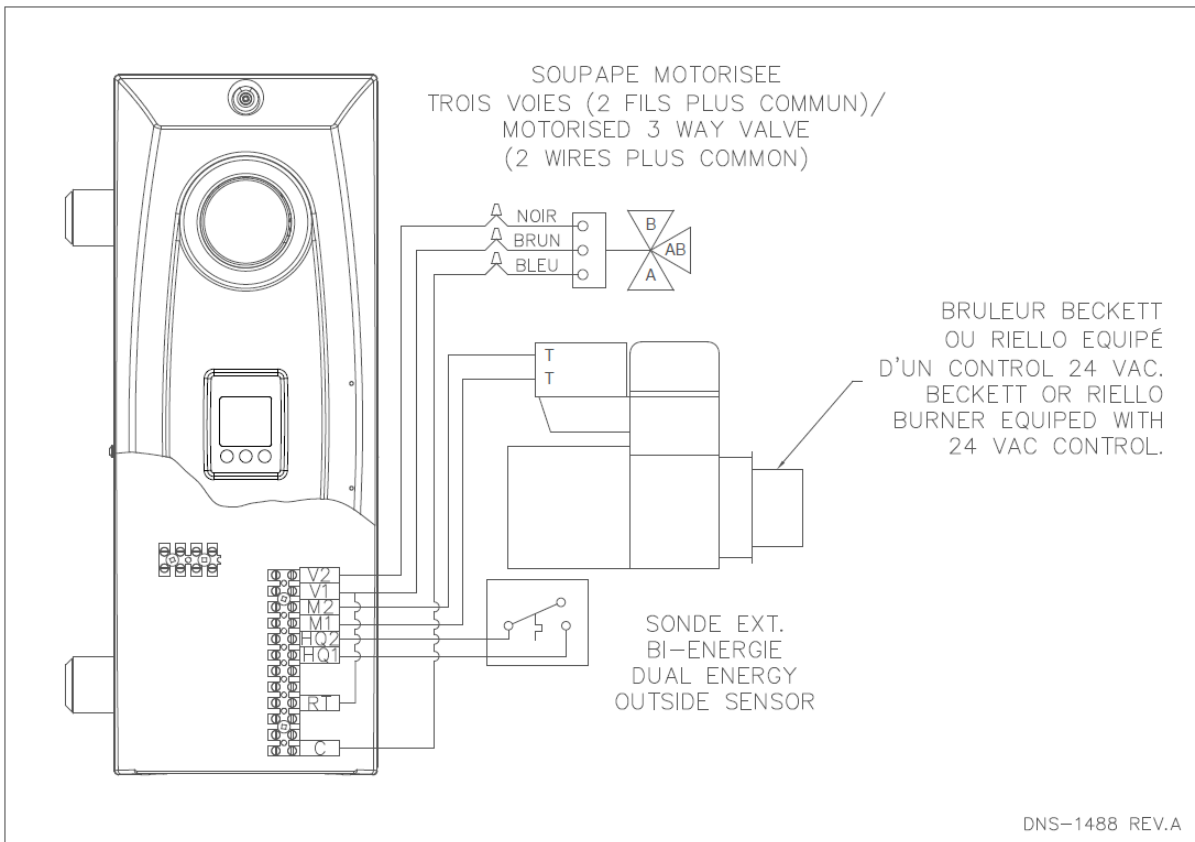

Figure 9 – Electrical Diagram

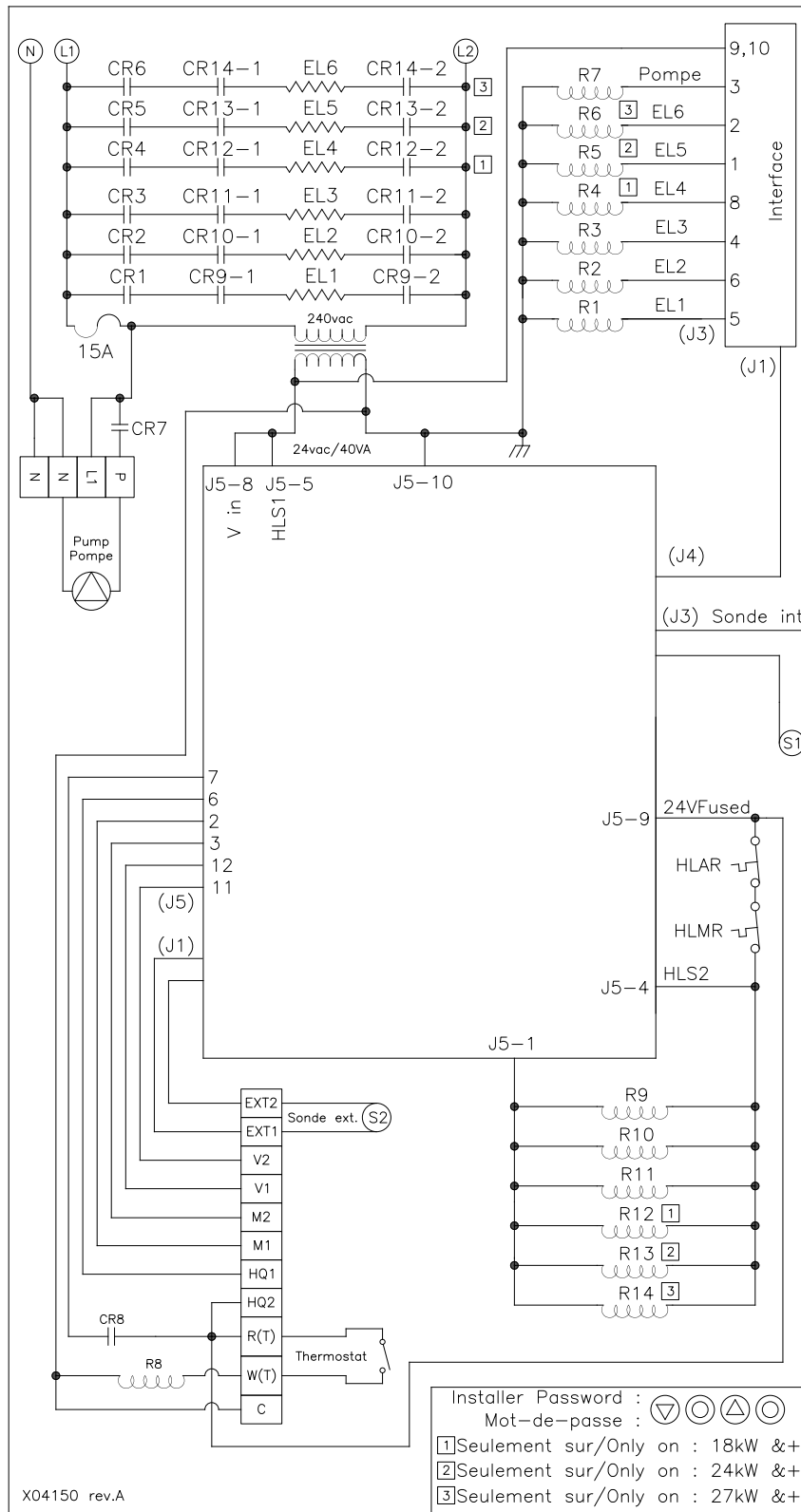
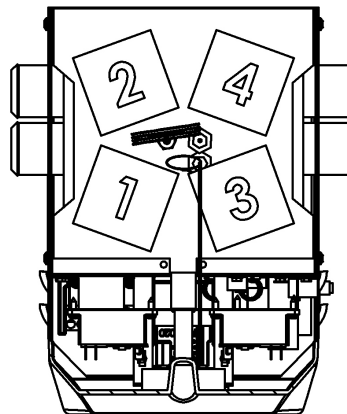
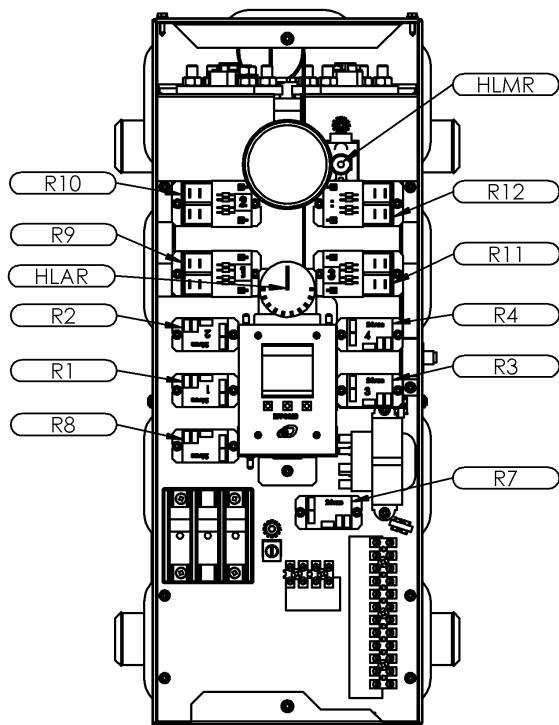
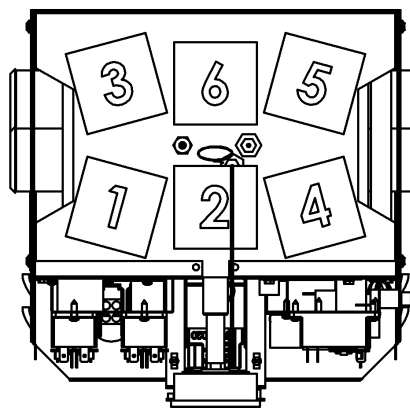
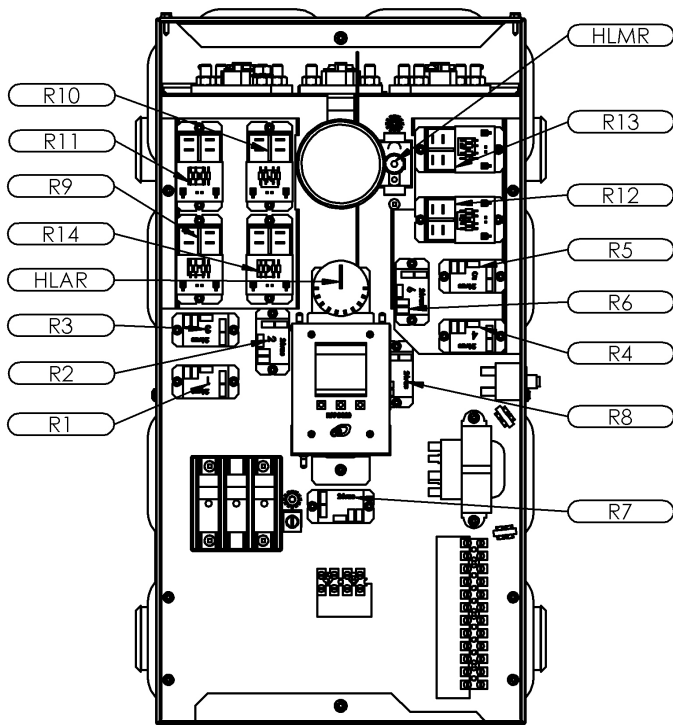

Figure 10 – Electrical Panel

15-20 KW



24-29 KW



DNS1493A

Figure 11 – Parts List

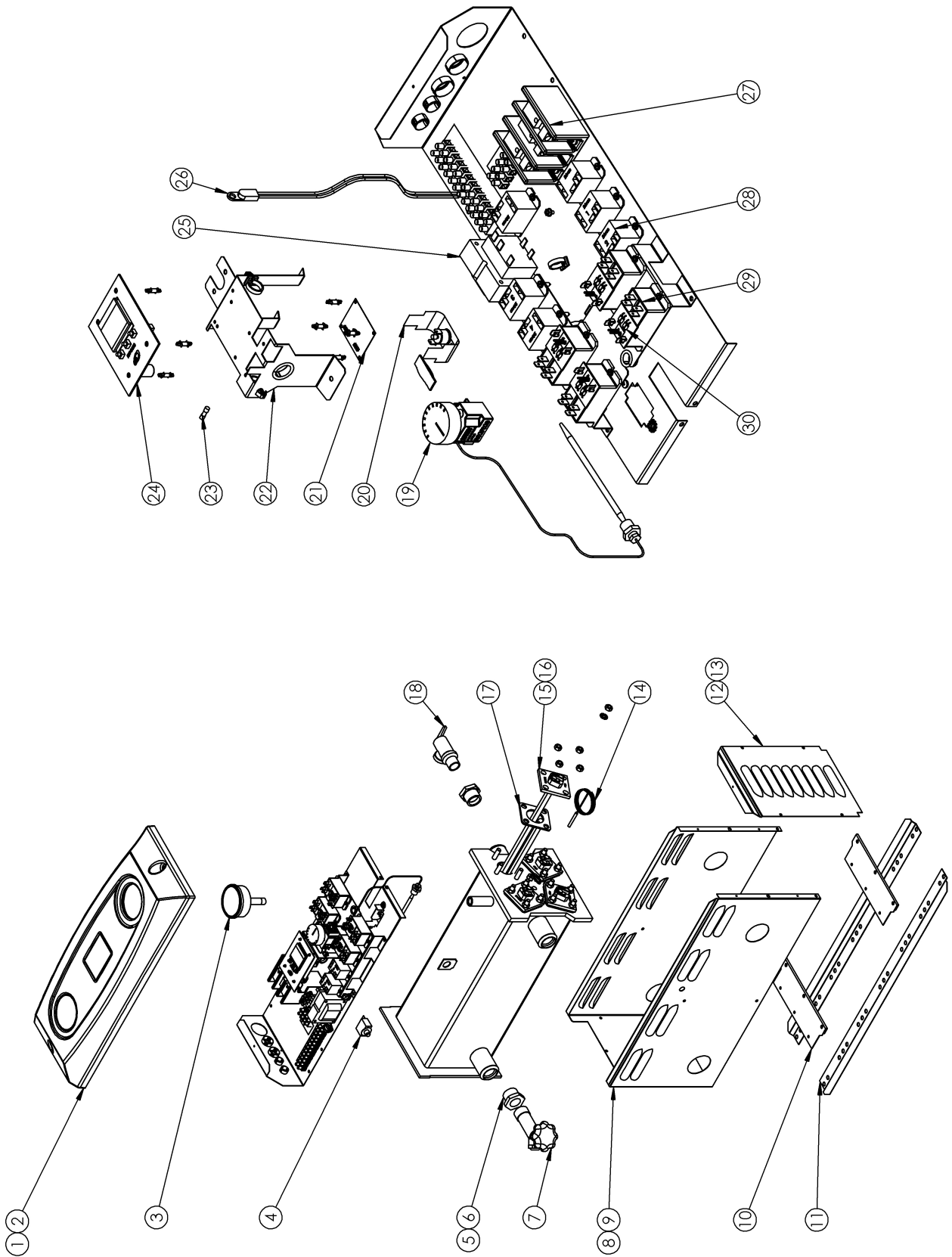

Table 5 – Parts List

#	Item	Description	Note
1	B04493	Cover assembly 15-20 kW	Cover, cosmetic and wiring diagram
2	B04494	Cover assembly 24-29 kW	Cover, cosmetic and wiring diagram
3	R02L007	Manometer	
4	L01J001	Breaker 15A	
5	G08F005	Reducer 1 x 3/4 Black	15-20 kW
6	G08F010	Reducer 1 1/4 x 3/4 Black	24-29 kW
7	G11Z002	Drain faucet 3/4m	
8	B04481	Jacket 15-20 kW	Painted steel
9	B04495	Jacket 24-29 kW	Painted steel
10	B04201	Machine bracket	
11	B03952	Wall bracket	
12	B04485	End plate 15-20 kW	
13	B04500	End plate 24-29 kW	
14	R02Z010	Temperature sensor	
15	B04237-02	Kit element 4 kW	Element and gasket
16	B04237-03	Kit element 5 kW	Element and gasket
17	B03970	Sealing gasket	
18	G11F025	Relief valve 30# 3/4m x 3/4f	
19	B04505	Aquastat	
20	B04487-01	Thermodisc support assembly	
21	K03082	Relay control board	Replacement kit
22	B04474	Control support	
23	L01G011	Fuse 2A	
24	K03083	Dettson control	Replacement kit
25	L01F010	Transformer 208/240V - 24V	
26	A20015	Exterior sensor -12 C	
27	L99F007	Terminal block	
28	L01H009	Control relay 24VAC	
29	L01H030	Relay DPST 22VDC	
30	R99G006	Rectifier control	

Table 6 – List of Wires

Item	Description	Note
A00223-14	Wire terminal P black	
A00330-08	Single wire terminal-relay red	15, 24 kW
A00330-09	Single wire terminal-relay black	15, 24 kW
A00330-10	Wire breaker black	
A00411	Wires neutral (N) white	
A00418-01	Wire terminal-relay-transformer red	
A00418-02	Double wire terminal-relay 14" black	
A00420	Wiring 120V black	
A00421-01	Wire exterior probe	
A00423-01	Flat wire	
A00437-05	Double wire terminal-relay red	24-29 kW
A00437-06	Double wire terminal-relay 6" black	
A00437-07	Double wire terminal-relay black	
A20009-06	Wire element black	
A20009-07	Wire element red	
A20024-06	Wire relay-relay red	4.5"
A20024-11	Wire relay-relay red	6"
B04476	24V wiring	15-20 kW
B04479	24V wiring	24-29 kW

Table 7 – Resistance Table of Temperature Sensors 10kΩ

Temp (°C)	Temp (°F)	Resistance (Ω)	Temp (°C)	Temp (°F)	Resistance (Ω)
-40	-40.0	336 479.00	33	91.4	7 098.00
-39	-38.2	314 904.00	34	93.2	6 808.00
-38	-36.4	294 848.00	35	95.0	6 531.00
-37	-34.6	276 194.00	36	96.8	6 267.00
-36	-32.8	258 838.00	37	98.6	6 015.00
-35	-31.0	242 681.00	38	100.4	5 775.00
-34	-29.2	227 632.00	39	102.2	5 545.00
-33	-27.4	213 610.00	40	104.0	5 326.00
-32	-25.6	200 539.00	41	105.8	5 117.00
-31	-23.8	188 349.00	42	107.6	4 917.00
-30	-22.0	176 974.00	43	109.4	4 725.00
-29	-20.2	166 356.00	44	111.2	4 543.00
-28	-18.4	156 441.00	45	113.0	4 368.00
-27	-16.6	147 177.00	46	114.8	4 201.00
-26	-14.8	138 518.00	47	116.6	4 041.00
-25	-13.0	130 421.00	48	118.4	3 888.00
-24	-11.2	122 847.00	49	120.2	3 742.00
-23	-9.4	115 759.00	50	122.0	3 602.00
-22	-7.6	109 122.00	51	123.8	3 468.00
-21	-5.8	102 906.00	52	125.6	3 340.00
-20	-4.0	97 081.00	53	127.4	3 217.00
-19	-2.2	91 621.00	54	129.2	3 099.00
-18	-0.4	86 501.00	55	131.0	2 986.00
-17	1.4	81 698.00	56	132.8	2 878.00
-16	3.2	77 190.00	57	134.6	2 774.00
-15	5.0	72 957.00	58	136.4	2 675.00
-14	6.8	68 982.00	59	138.2	2 579.00
-13	8.6	65 246.00	60	140.0	2 488.00
-12	10.4	61 736.00	61	141.8	2 400.00
-11	12.2	58 434.00	62	143.6	2 316.00
-10	14.0	55 329.00	63	145.4	2 235.00
-9	15.8	52 407.00	64	147.2	2 157.00
-8	17.6	49 656.00	65	149.0	2 083.00
-7	19.4	47 066.00	66	150.8	2 011.00
-6	21.2	44 626.00	67	152.6	1 942.00
-5	23.0	42 327.00	68	154.4	1 876.00
-4	24.8	40 159.00	69	156.2	1 813.00
-3	26.6	38 115.00	70	158.0	1 752.00
-2	28.4	36 187.00	71	159.8	1 693.00
-1	30.2	34 368.00	72	161.6	1 637.00
0	32.0	32 650.00	73	163.4	1 582.00
1	33.8	31 029.00	74	165.2	1 530.00
2	35.6	29 498.00	75	167.0	1 480.00
3	37.4	28 052.00	76	168.8	1 432.00
4	39.2	26 685.00	77	170.6	1 385.00
5	41.0	25 392.00	78	172.4	1 340.00
6	42.8	24 170.00	79	174.2	1 297.00
7	44.6	23 013.00	80	176.0	1 255.00
8	46.4	21 918.00	81	177.8	1 215.00
9	48.2	20 882.00	82	179.6	1 177.00
10	50.0	19 901.00	83	181.4	1 140.00
11	51.8	18 971.00	84	183.2	1 104.00
12	53.6	18 090.00	85	185.0	1 070.00
13	55.4	17 255.00	86	186.8	1 037.00
14	57.2	16 463.00	87	188.6	1 005.00
15	59.0	15 712.00	88	190.4	973.80
16	60.8	14 999.00	89	192.2	944.10
17	62.6	14 323.00	90	194.0	915.50
18	64.4	13 681.00	91	195.8	887.80
19	66.2	13 072.00	92	197.6	861.20
20	68.0	12 493.00	93	199.4	835.40
21	69.8	11 942.00	94	201.2	810.60
22	71.6	11 419.00	95	203.0	786.60
23	73.4	10 922.00	96	204.8	763.50
24	75.2	10 450.00	97	206.6	741.20
25	77.0	10 000.00	98	208.4	719.60
26	78.8	9 572.00	99	210.2	698.70
27	80.6	9 165.00	100	212.0	678.60
28	82.4	8 777.00	101	213.8	659.10
29	84.2	8 408.00	102	215.6	640.30
30	86.0	8 057.00	103	217.4	622.20
31	87.8	7 722.00	104	219.2	604.60
32	89.6	7 402.00	105	221.0	587.60