

Installation Instructions and Homeowner's manual



Models:

HYDRAC03-E2401M
HYDRAC04-E2401M
HYDRAC05-E2401M
HYDRAC06-E2401M
HYDRAC07-E2401M
HYDRAC08-E2401M
HYDRAC09-E2401M
HYDRAC10-E2401M
HYDRAC11-E2401M
HYDRAC12-E2401M

Attention

Do not tamper with the unit or its controls. Call a qualified service technician.

Manufactured by :
Dettson Industries Inc.
Sherbrooke (Quebec) Canada
<http://www.dettson.ca/>



ELECTRIC BOILER ELECTRONIC CONTROL



INSTALLER / TECHNICIAN :

USE THE INFORMATION IN THIS MANUAL FOR THE INSTALLATION / SERVICING OF THE BOILER AND KEEP THE DOCUMENT NEAR THE UNIT FOR FUTURE REFERENCE.

HOMEOWNER :

PLEASE KEEP THIS MANUAL NEAR THE BOILER FOR FUTURE REFERENCE.

TABLE OF CONTENT

SECTION 1. INSTALLATION.....3	2. Connecting the thermostat6
1) Danger, warning and caution3	3. Connecting the temperature sensor6
2) Heating with hot water.....3	SECTION 2. OPERATION7
3) Delivery3	1) Adjustments and start-up.....7
4) Installation3	2) Mechanical high limit7
5) Clearance4	3) Electronic control7
6) Distribution System4	SECTION 3. MAINTENANCE12
7) Installation of the boiler5	SECTION 4. INFORMATION12
8) Electric power supply6	SECTION 5. TECHNICAL DATA.....13
1. Connecting the circulating pump.....6	SECTION 6. REPLACEMENT PARTS.....16

LIST OF FIGURES

Figure 1: Mounting configurations4	4
Figure 2: Boiler components.....5	5
Figure 3: Navigation in menus.....9	9
Figure 4: Modulation in function of the exterior temperature11	11
Figure 5: Boiler Dimensions13	13
Figure 6: Typical Diagram of a Single Zone Installation14	14
Figure 7: Multizone Diagram with more than one Circulator.....14	14
Figure 8: Multizone diagram with Motorized Valves15	15
Figure 9: Electrical Diagram15	15
Figure 10: Exploded View.....16	16

LIST OF TABLES

Table 1: Minimum clearances to combustible materials4	4
Table 2: Alarm description.....10	10
Table 3: Hydra Compact – Technical specifications13	13
Table 4: Parts List17	17

SECTION 1. INSTALLATION

1) DANGER, WARNING AND CAUTION

The words DANGER, WARNING and CAUTION are used to identify the levels of seriousness of certain hazards. It is important that you understand their meaning. You will notice these words in the manual as follows:



DANGER

Immediate hazards which WILL result in death or serious injury.



WARNING

Hazards or unsafe practices which CAN result in death or injury.

CAUTION

Hazards or unsafe practices which CAN result in personal injury, product or property damage.

2) HEATING WITH HOT WATER

Your HYDRA electric boiler was carefully assembled and checked in our plant, so that it will deliver warmth and comfort to your home for many years to come.

This manual is intended to provide the necessary information for the installation of the unit, how it functions and explains security measures which are particular to this type of equipment.

It is essential that the persons installing, operating or adjusting the boiler carefully read this manual, in order to completely understand and be familiar with the procedures to be followed.

Any questions relative to the operation, maintenance or guarantee should be directed to the company where the equipment was purchased.

Upon completion of the installation, this manual should be placed back into its original envelope and kept near the boiler for future reference.

3) DELIVERY

Upon delivery of the boiler, check the nameplate to be sure that you have received the model with the correct rating and proper voltage.

The following items are supplied with the unit:

- A pressure relief valve, adjusted to 30 psi;
- A drain valve;
- An exterior probe for modulation;
- Two 1" x 3/4" reducers for the pressure relief valve and the drain valve.

4) INSTALLATION



WARNING

The installation of this unit must be performed by a qualified technician and it must conform to the standards and regulations in force as well as the Canadian Installation Code for Hydronic Heating Systems CSA B214-01.

POSITIONING

The unit must be installed in an area that is dry, non-corrosive, without excessive dust, well ventilated and where the ambient temperature does not exceed 27°C (80°F).

The boiler must be installed using the mounting brackets that are included. Before all, unfold the four lugs at the back of the unit. First, position the upper support, hang the boiler, then fix the down support. Finally, use the included self-tapping screws to fix the unit to the wall brackets with the lugs.

The boiler can be installed in 5 possible configurations as shown in Figure 2.

Ensure that it is installed level and that the clearances indicated in Table 1 are respected.

Figure 1: Mounting configurations

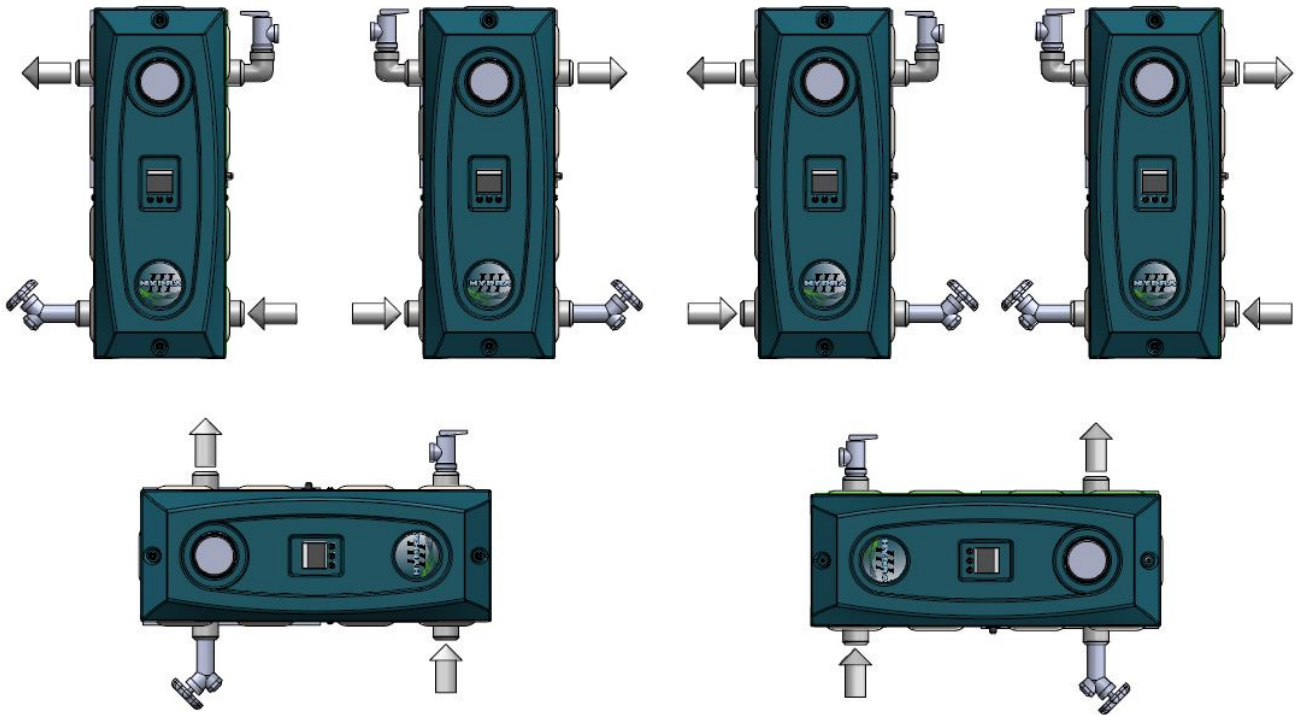

DNS1489D

5) CLEARANCE

The following clearances should be provided for the servicing of the unit:

Table 1: Minimum clearances to combustible materials

LOCATION	CLEARANCE
Access side to elements	13 1/4" (34 cm)
Sides	4" (10 cm)
Bottom	0
Front*	0
Back	0

* If the boiler is in an enclosure, provide a door or a removable panel in front to access the control panel.

6) DISTRIBUTION SYSTEM

The proper functioning of your heating system is directly related to the quality of the plumbing installation. Therefore, the entire installation must be performed by qualified technicians.

See Figure 2 for the functions of the various boiler components.

The heating system must be set-up to operate at a maximum pressure of 28 psi and the operating temperature may range from 5°C to 88°C (41°F to 190°F).

Figure 2: Boiler components

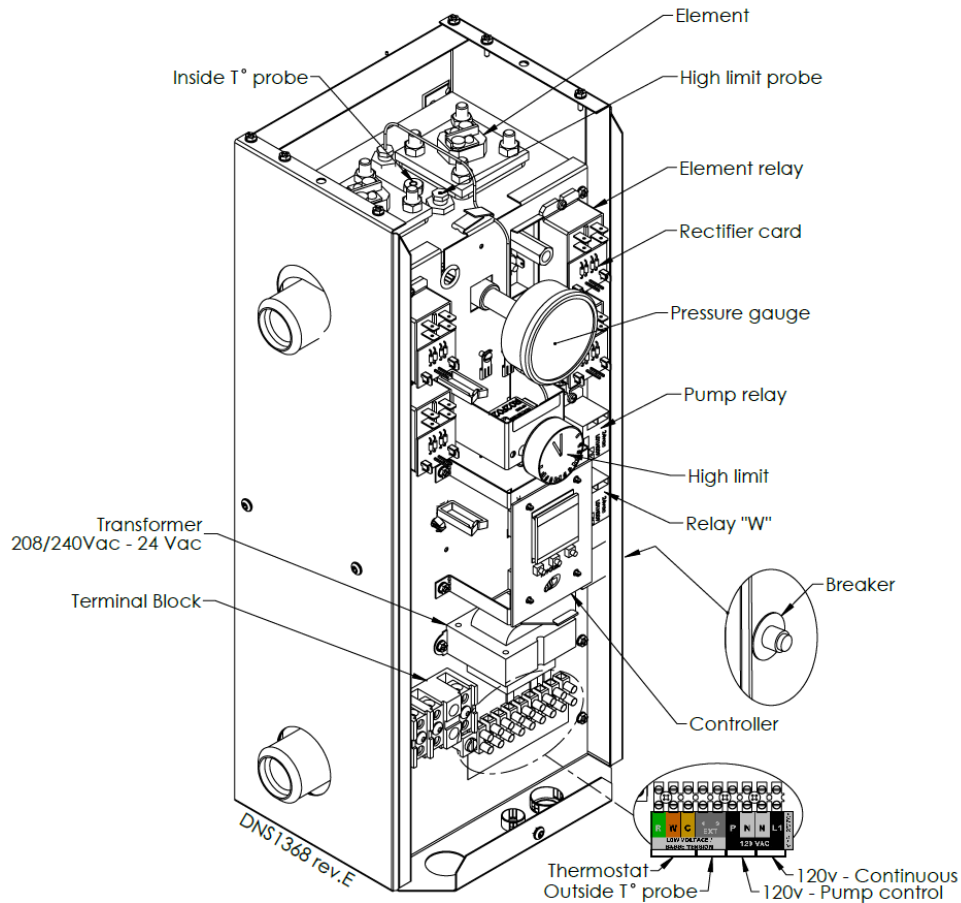

Freeze protection (when required)

WARNING

Only propylene glycol may be used in this hydronic heating system, to prevent freezing. It is recommended to add a maximum of 50% of propylene glycol mixture to ensure proper operation.

Do not use automotive anti-freeze, ethylene glycol or any undiluted anti-freeze.

If the above recommendations are not followed, severe personal injury, death or substantial property damage can result.

All installations must include the following items:

- a. 1 pressure regulator, adjusted to 12 psi, must be installed between the boiler and the main water supply in the building;

- b. 1 expansion tank, pre-pressurized to 12 psi and of appropriate size;
- c. 1 or more automatic air purge valves;
- d. 1 or more circulating pumps of appropriate capacity.

CAUTION

To avoid water damage and/or scalding due to relief valve operation, a discharge line must be connected to the valve outlet and run to a drainage area. The discharge line shall be installed in such a way that it will allow for the complete drainage of the valve and the discharge line.

7) INSTALLATION OF THE BOILER

At the time of installation, the following steps should be followed. Refer to Figure 5, Figure 6, Figure 7, Figure 8 and Figure 9.

- 1. Choose an appropriate location. Mount the boiler securely on the wall, with the help of the mounting plate. Ensure that it is level and that the minimum clearances are observed;

2. Install the drain valve and the safety valve according to the mounting configuration as shown in Figure 1;
3. Install the water supply and return piping with the 1" NPT fitting;
4. The heating supply line must include:
 - a. 1 circulator along with 2 maintenance valves;
 - b. 1 automatic pressure reducing valve adjusted to 12 psi, with a shut-off valve on the return water line;
 - c. 1 expansion tank;
 - d. 1 automatic vent.
5. In order to ensure satisfactory water flow, the friction in the piping system must not exceed the capacity of the circulator;
6. After having completed all piping connections, run water through the system and purge the air. The automatic vent should be in operation.

Warning: Remove the plastic cover and check to see if the elements are watertight.

8) ELECTRIC POWER SUPPLY

All electrical wiring must conform to the standards and regulations in force and the Canadian Electrical Code CSA C22.1.

Electrical power to the boiler must come from a 120/240V 60 Hz or 208V 60 Hz, single phase, 3-wire, grounded circuit, protected by an appropriately sized breaker, based on the total rating of the boiler. When using 208V, change the connector's position at the primary of the transformer. Refer to the boiler nameplate and the technical specifications in this manual to select the proper breaker and wire size.



WARNING

RISK OF FIRE.

The conductor sizing must conform to the last edition of the local or national codes.

Failure to follow this rule can result in death, bodily injury and/or property damage.

Power supply to the unit can be made using copper or aluminium wires. The wire size must be decided in accordance to unit power consumption, the over current protection type and capacity, the wire type and length, and the environment where the unit is installed. If an aluminium wire is used, other precautions (such as the use of a DE-OX inhibitor) must be taken to insure the conformity of the installation. In all cases, all the factors affecting the wire gauge must be considered and the installation codes followed.

The exterior of the unit must have an uninterrupted ground to minimize the risk of bodily harm. A ground terminal is supplied with the control box for that purpose.

In the event that wires inside the unit require replacement, these must be as same type as originals. (Copper wiring only)

1. Connecting the circulating pump

Connect the circulating pump on 120V connections points identified P-P in the control panel as shown in Figure 2. The electronic control is designed to operate the circulator on thermostat demand, with a heat purge delay at the end of heating cycle or continuous flow. Refer to the electronic control section to learn how to configure this function.

2. Connecting the thermostat

Single heating zone

Connect the low voltage thermostat to R-W terminals located inside the control panel. See Figure 4.

Multiple heating zones

Connect the contacts of the motorized valves or pump controls to R-W terminals inside the control panel. See Figure 5 and Figure 6.

3. Connecting the temperature sensor

Mount the sensor on an outside wall, protected from direct sunlight, so that it will accurately measure the outside temperature. Install 2 only #20 wires between the outdoor sensor and the terminals identified as S-EXT and S-EXT inside the control panel of the boiler.

SECTION 2. OPERATION

1) ADJUSTMENTS AND START-UP

CAUTION

The boiler must be filled with water and all air purged from the system, before turning on the power.

CAUTION

If the power is turned on before the boiler is filled with water, the elements will become seriously damaged.

- 1 Turn on the power,
- 2 Adjust the set point of the boiler on the electronic control. See control section for adjustments.
- 3 Set the thermostat at 30°C (85°F). The circulator should start as well as the electrical elements in sequence with a 12 seconds delay;
- 4 The circulator stays on for as long as there is a call for heat except if differently configured on the electronic control.

2) MECHANICAL HIGH LIMIT

Mechanical High Limit Control

The mechanical limit aquastat must be set 30°F above the set point temperature on the electronic control.

Manual reset high limit control

Disconnect the unit before resetting the high limit. The manual reset high limit is set at 100°C (212°F). To reset this protection, the boiler needs to cool down. Then the red button shall be pressed using a pen or screwdriver.

3) ELECTRONIC CONTROL

Display and electrical controller:

```
PUMP : OFF
SET P : 149.0 °F
TARGET: 149.0 °F
T° IN : 62.5 °F
T° OUT : UNUSED
Cmd : 0%
```

PUMP: Shows the state of the pump.

SET P: Indicates the temperature set point.

TARGET: Indicates the target temperature.

T° IN: Temperature inside of the device.

T° OUT: Temperature outside of the device

Cmd: Indicates the percentage of power sent to the elements

From this screen and by pressing the directional buttons, the user can switch from the various menus available and press the central button to access the desired menu.

These menus are the consumption menu, the alarm menu, the configuration menu and the installer menu.

Consumption:

CONSUMPTION

```
APPROX: 13.2kWh
12 hours ago
press o to reset
```

The consumption menu shows an approximated value of the power consumed by the boiler since it was last reset.

Consumption is written in kilowatt hour and time since last reset is given in hours or in days.

As shown on the screen, pressing the central button will reset the time and power consumed.

Alarm:

Some events may alter the functionality of the device in an undesired manner. These events trigger alarms in the system that remains stored in the device's memory. Reasons for alarms are: troubles with the internal or the external heat sensor, problems with elements and overheating.

In case of alarm, the controller's screen will be illuminated by a flashing red light. It is strongly advised that you tell an installer about this issue.

Using the left and right buttons, the arrow on the screen can be moved and the central button will allow the user to activate the element pointed by it.

```
ALARM
-> CURRENT
PAST
CLR. ALARM
BACK
```

Current: Indicate the alarms currently afflicting the device.

Past: Shows a history of the alarms triggered on the device.

Clear alarm: Ends alarms that still appear active on the device.

The past alarm function allows you to revisit the previous 25 alarm messages and an approximated time span since they happened. The arrow buttons allow the user to scroll through the alarm reports and the central button allows them to return to the alarm menu.

```
ALARM
Error #1
Err. int. sensor
2 hours ago
```

Configuration:

The configuration menu's purpose is to allow the user to adjust settings linked to the interface, such as the temperature's units and the language.

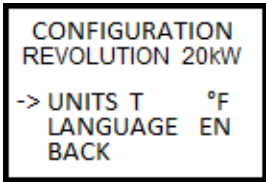

UNITS: allows switching between Fahrenheit and Celsius degrees.

LANGUAGE: allows switching the displayed text between French and English.

Important: Access to the **TESTS** tab appearing on the controller's screen is protected by a password. Under no circumstances should a user try to access it. This function is used at the Dettson factory to test the Hydra Revolution before it is shipped to a distributor. If the user manages to enter the correct password the machine will be stuck in the test function. To exit the test function, the machine must be shut down, it will then return to the main screen after being subsequently turned on.

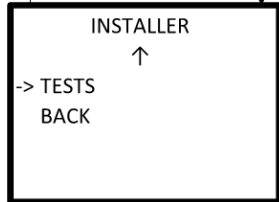

Installer:



The installer menu's goal is to make the installer's work easier. This menu is protected by a password that can be found on the electrical schematic glued to the plastic case of the Hydra Compact.

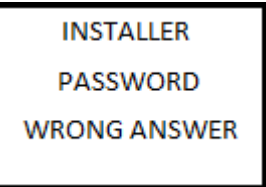

The password consists of a combination of characters entered with the three buttons of

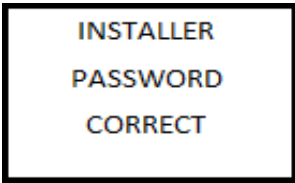

the Hydra (left, center, right then center).



The user shouldn't try to gain access to this menu as it is used to program the behaviour of the device.

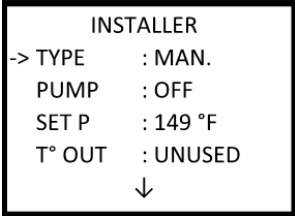

TYPE: Gives a preset value to the temperature set point. Mass, Plinth, Light and Cast Iron are preset values for determining temperature ceil. Manual allows the installer to manually choose the set point.

PUMP: Choose the way to drive the pump. Off means the pump will activate only when there is a demand from the thermostat. "On" means that the pump will always be active. 20 Seconds indicate that the pump will deactivate 20 seconds following the end of a heating demand from the thermostat.

SET P: Set the target temperature the device will try to reach upon the reception of a signal from the thermostat.

T° OUT: Allows the device to know if an external sensor is being used.

Boost Mode:

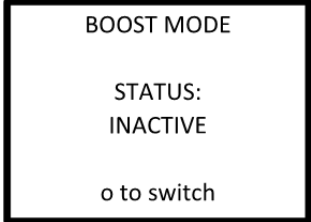

The boost mode menu allows the user to raise the boiler's temperature set point by 10 degrees Fahrenheit during 24 hour. Press the central button while in this menu to activate or deactivate this measure.

Figure 3: Navigation in menus

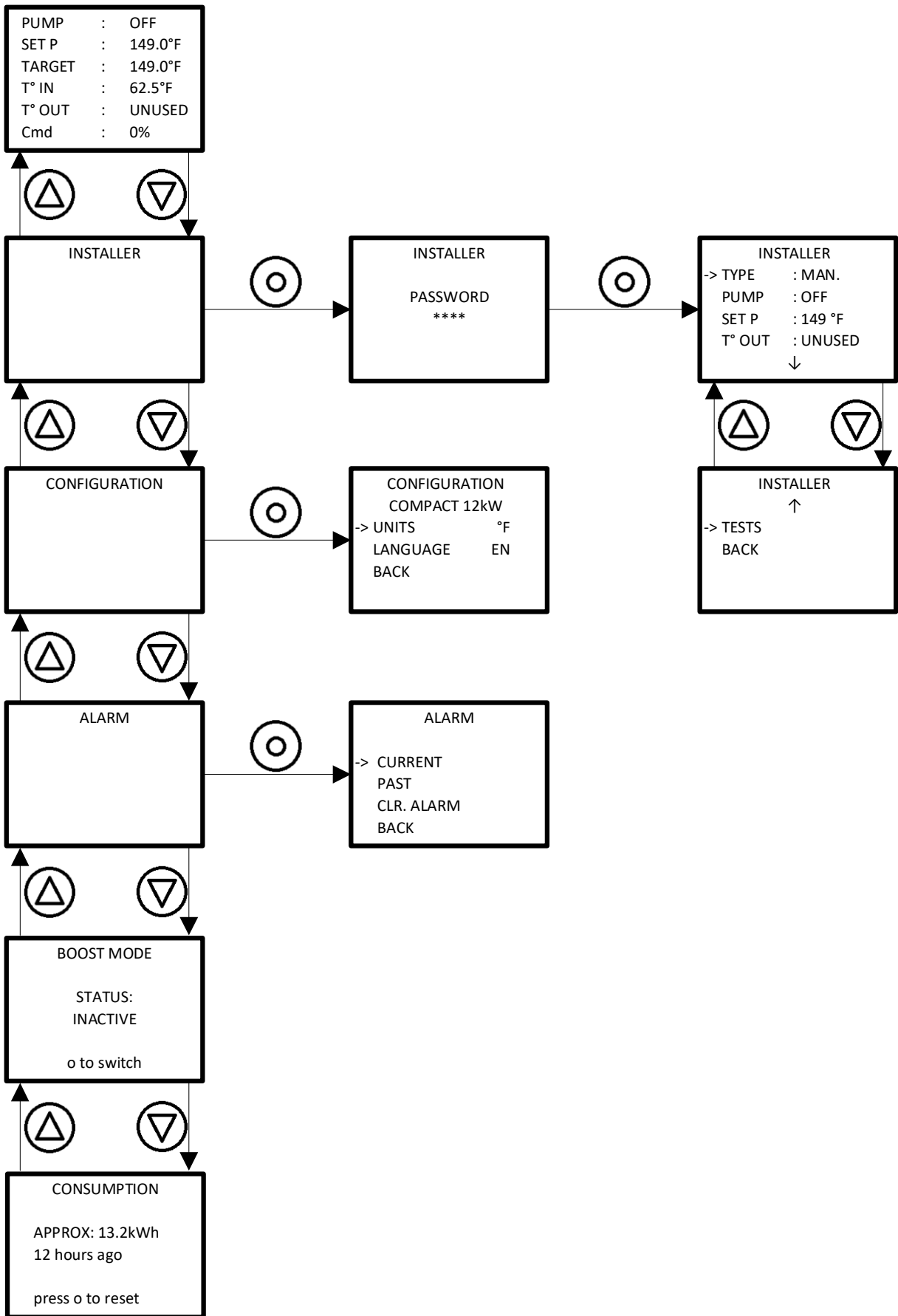
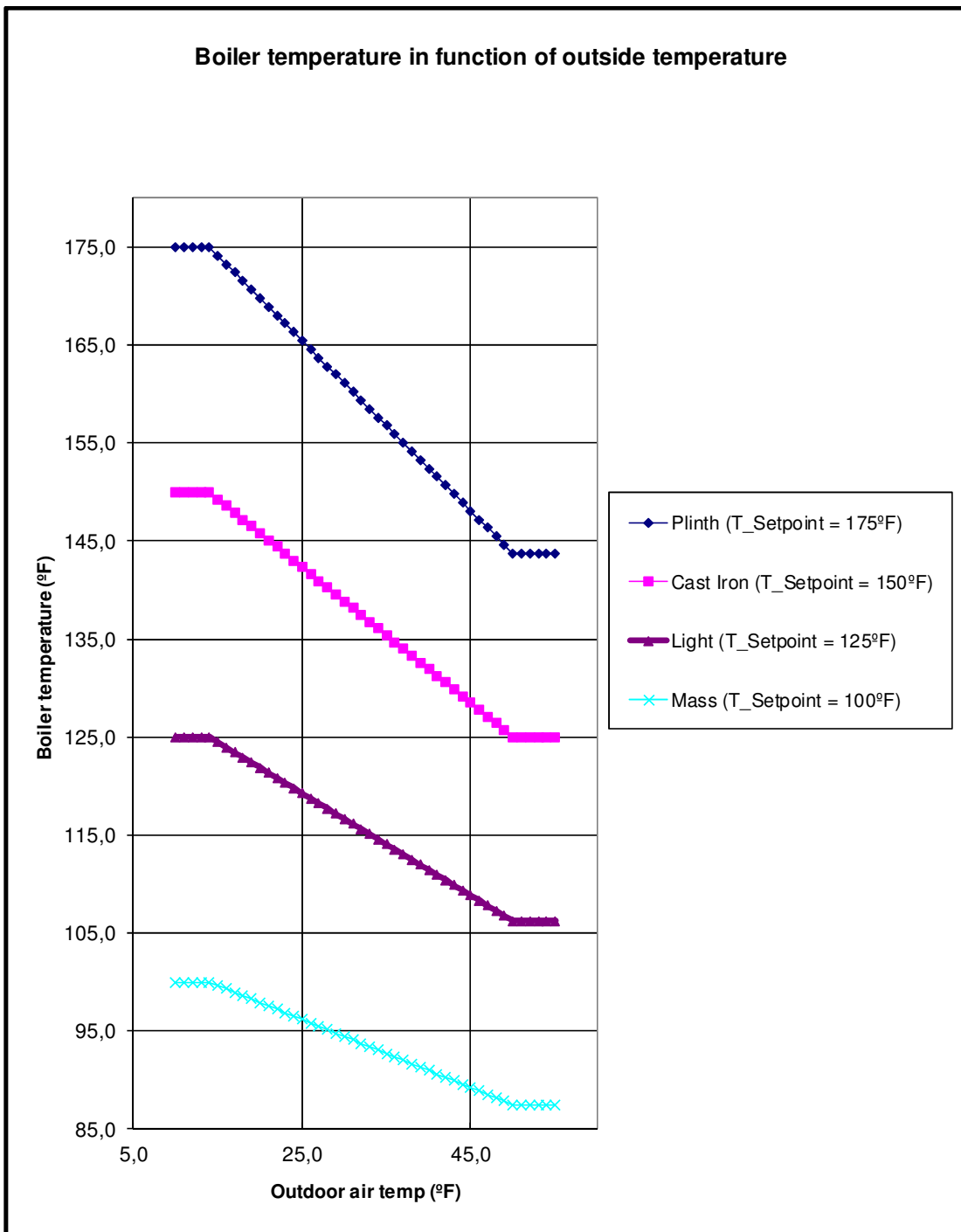

Table 2: Alarm description

Alarme	Description	Possible cause
<i>T in</i>	<i>The boiler temperature sensor returns a temperature that is not within standard values</i>	<i>Misconnected sensor T in and T ext inverted Damaged wire</i>
<i>T out</i>	<i>The outdoor temperature sensor returns a temperature that is not within standard values</i>	<i>Misconnected sensor T in and T ext inverted Damaged wire</i>
<i>Overheat</i>	<i>The control is experiencing an increase in temperature when it does not send command to elements</i>	<i>Remaining heat in system Oil boiler active in dual energy systems Defective relay or element</i>
<i>Element</i>	<i>The temperature in the boiler does not increase at a standard rate</i>	<i>The load is more important than usual (large house, concrete floor, beginning of season) Not all the elements are heating Make sure the current drawn by the unit corresponds to the one on the rating plate</i>

Figure 4: Modulation in function of the exterior temperature



SECTION 3. MAINTENANCE

The property owner has the following responsibilities:

- a. To maintain the area around the boiler clean at all times and free from combustible and highly flammable material;
- b. To ensure that the ambient air at the boiler is not excessively dusty or humid;
- c. To have all water leaks repaired in the system as they arise.
- d. To ensure that the ambient temperature in the area where the unit is installed does not exceed 27°C (80°F).

It is recommended that the boiler be purged annually, in order to eliminate sediment and sludge that may have accumulated at the bottom of the boiler and covered the heating elements.

Procedure:

1. Let the boiler cool down;
2. Close the maintenance valves, which are installed at the water inlet and outlet of the boiler. N.B.: It is not recommended to drain the water from the heating pipe system;
3. Hook-up a garden hose to the drain valve and place it close to a floor drain;
4. Open the purge valve until the water comes out clean and clear;
5. Close the valve.

It is recommended to perform a visual inspection of the boiler electrical compartment annually, during the heating season. The items to check are the water tightness of the elements, signs of overheating of the electrical components and the wiring. Corrective measures must be undertaken as required, as soon as possible.

Defective components should always be replaced with the Original Equipment Manufacturer's parts.

CAUTION

The boiler guaranty may be invalidated if: water leaks in the system are not repaired; the boiler is used as a source of domestic hot water or a significant amount of new water or air is introduced into the system.

SECTION 4. INFORMATION

Model: _____ Serial number: _____

Installation date of the electric boiler: _____

Service telephone # – Day: _____ Night: _____

Dealer name and address: _____

SECTION 5. TECHNICAL DATA

Table 3: Hydra Compact – Technical specifications

POWER (kW@208V)		Volts - Hertz - Phase	Electric element #1 (Kw)	Electric element #2 (Kw)	Consumption (Amp 208/240)	Circuit Amperage (wire sizing)	GENERAL INFORMATIONS	Supply - Return	Minimum water flow USG/min	Overall Dimensions (width x deep x height)	Shipping weight
POWER (kW@240V)								1" NPT female			
2.25	3	208 / 240 - 60 - 1	3	-	9.4 / 12.5	12 / 15.6		0.81 / 1.08 1.08 / 1.44 1.35 / 1.81 1.63 / 2.17 1.90 / 2.53 2.17 / 2.89 2.44 / 3.25 2.71 / 3.61 2.98 / 3.97 3.25 / 4.33	8 3/16" X 8 7/16" X 21 3/4"	44 lb (20 kg)	
3	4		4	-	12.5 / 16.7	15.6 / 20.9					
3.75	5		5	-	15.6 / 20.8	19.5 / 26					
4.5	6		3	3	18.8 / 25.0	23.5 / 31.3					
5.25	7		4	3	21.9 / 29.2	27.4 / 36.5					
6	8		4	4	25 / 33.3	31.3 / 41.6					
6.75	9		5	4	28.2 / 37.5	35.3 / 46.9					
7.5	10		5	5	31.3 / 41.7	39.1 / 52.1					
8.25	11		6	5	34.4 / 45.8	43 / 57.3					
9	12		6	6	37.6 / 50.0	47 / 62.5					

In all cases, refer to applicable local and national codes.

Figure 5: Boiler Dimensions

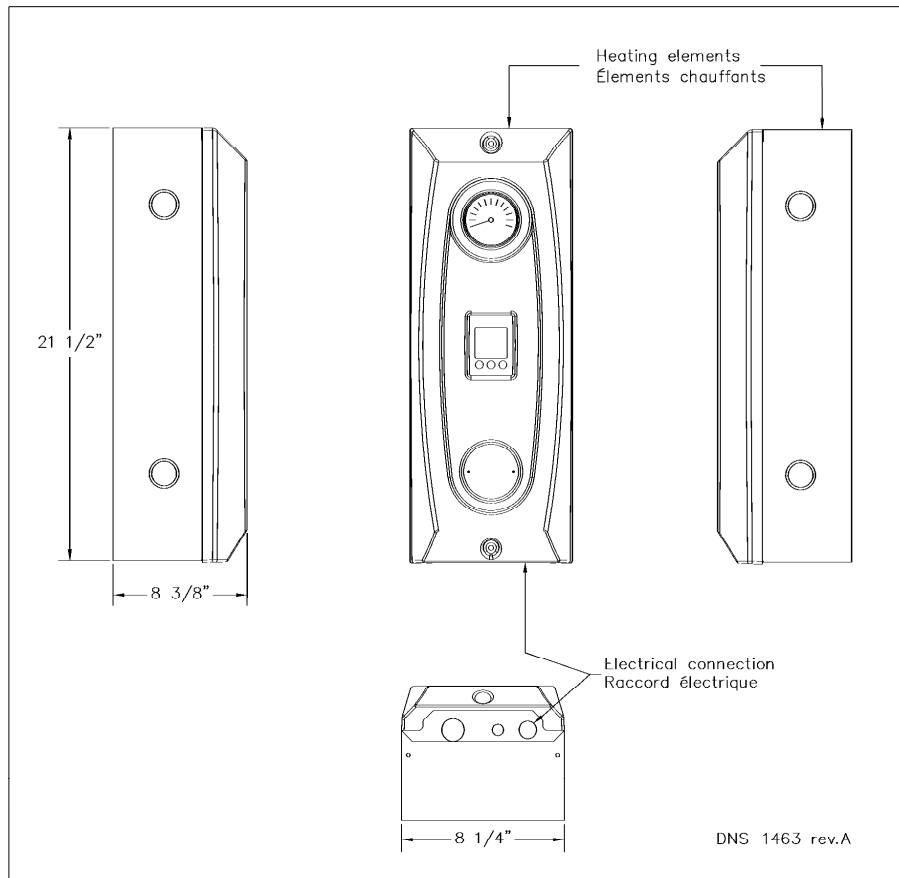

Figure 6: Typical Diagram of a Single Zone Installation

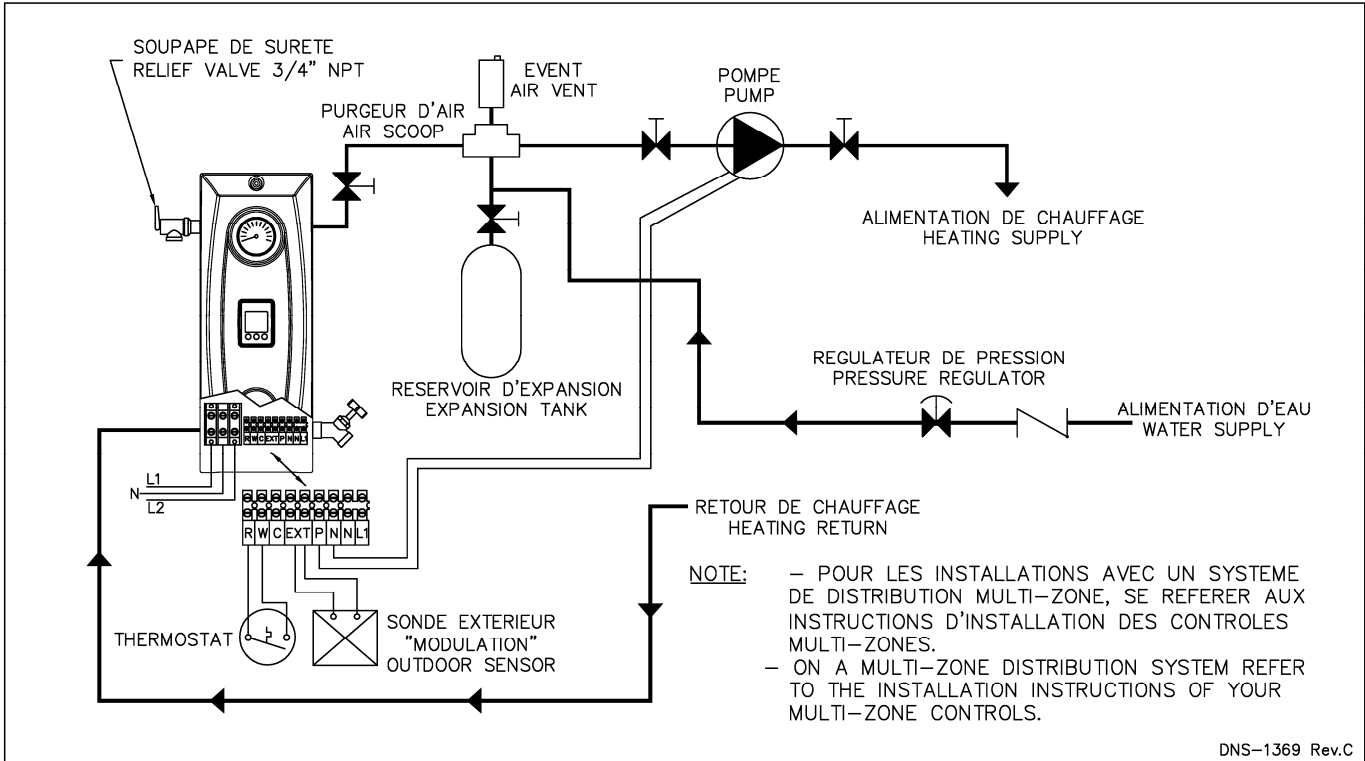

Figure 7: Multizone Diagram with more than one Circulator

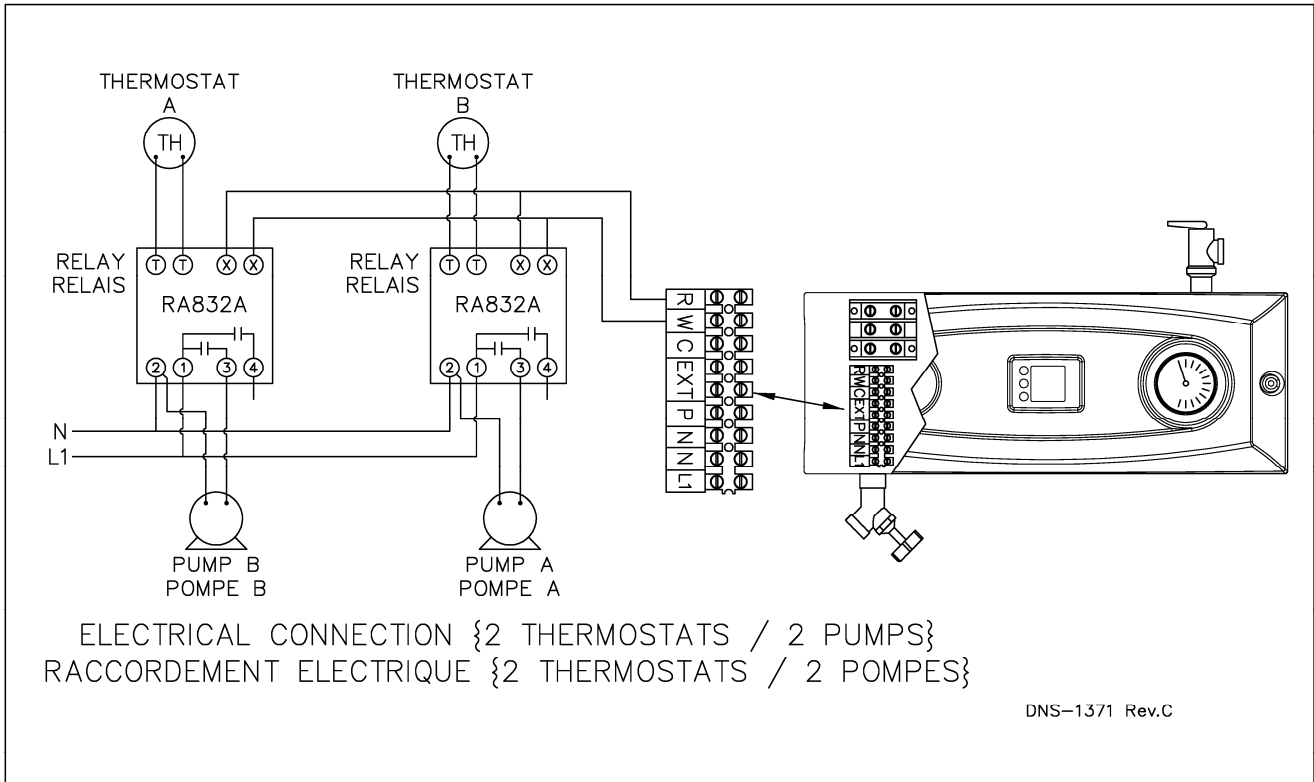

Figure 8: Multizone diagram with Motorized Valves

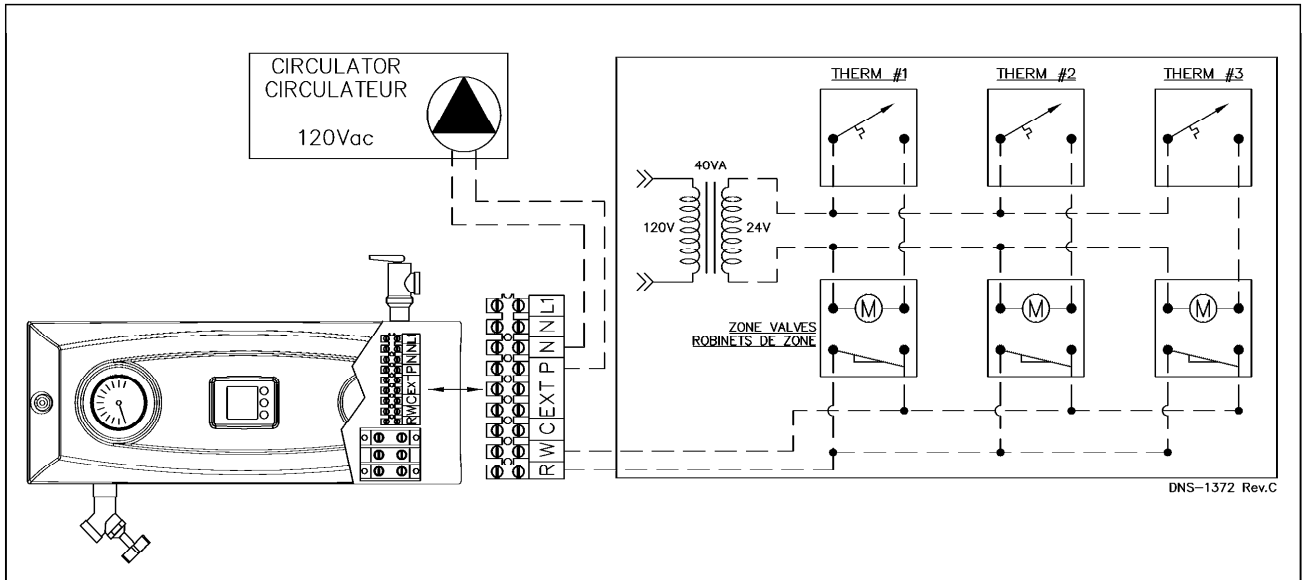
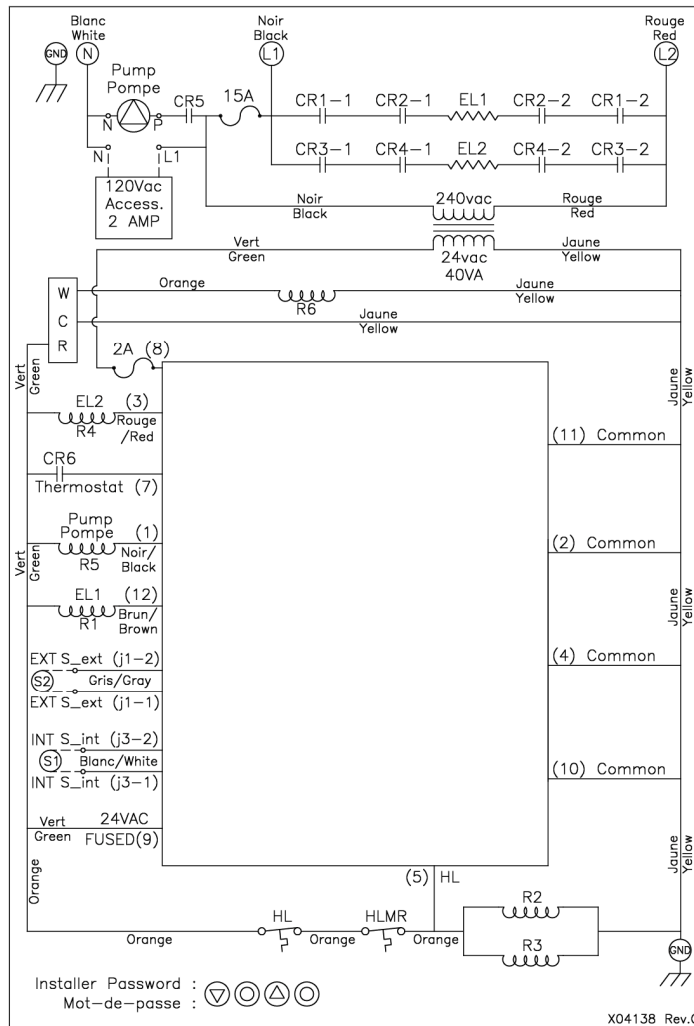
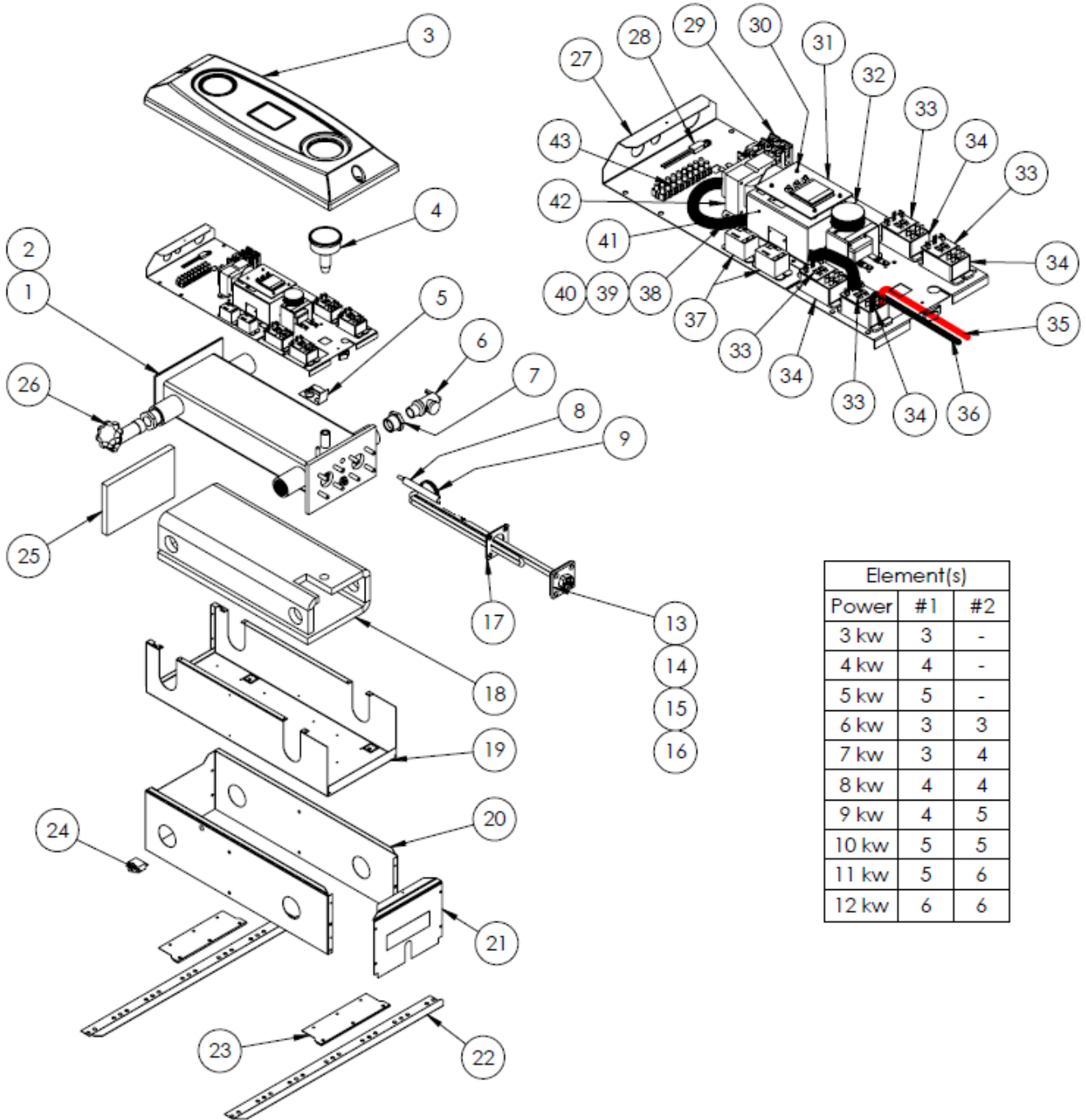

Figure 9: Electrical Diagram



SECTION 6. REPLACEMENT PARTS

Figure 10: Exploded View



Element(s)		
Power	#1	#2
3 kw	3	-
4 kw	4	-
5 kw	5	-
6 kw	3	3
7 kw	3	4
8 kw	4	4
9 kw	4	5
10 kw	5	5
11 kw	5	6
12 kw	6	6

B50120 Rev. E

Table 4: Parts List

#	Item	Description	Comments
1	B04383-02	Tank	3kw @ 5kw (Tank only)
2	B04383-01	Tank	6kw @ 12kw (Tank only)
3	B04422	Cover assembly	Cover, cosmetic and wiring diagram
4	R02L007	Manometer	
5	B04180-01	Thermodisc support assembly	Thermodisc, support and heat paste
6	G11F025	Relief valve 30# 3/4m x 3/4f	
7	G08F005	Adaptor 1 x 3/4	
8	R02J013	Well probe 1/4 NPT	
9	R02Z010	Temperature probe	
13	B04237-01	Element replacement kit	Element 3 kw and gasket
14	B04237-02	Element replacement kit	Element 4 kw and gasket
15	B04237-03	Element replacement kit	Element 5 kw and gasket
16	B04237-04	Element replacement kit	Element 6 kw and gasket
17	B03970	Sealing gasket element	
18	B04401	Insulation	
19	B04395	Cabinet	
20	B04398	Jacket	
21	B04391	End plate assembly	
22	B03952	Wall support	
23	B04201	Machine support	
24	L01J001	Breaker 15amp	
25	B04400	End plate insulation	
26	G11Z002	Drain faucet 3/4m	
27	B04396	Electrical panel	Panel only
28	A20015	Exterior probe -12 deg.C	
29	L99F006	Terminal block	
30	F14G007	Nylon standoff	
31	R99G020	Dettson control	
32	B04184	Aquastat assembly (Hi-limit)	
33	R99G006	Rectifier control	
34	L01H030	Relay DPST 22VDC	
35	A20009-05	Red wire element	
36	A20009-04	Black wire element	
37	L01H009	Relay 24vac	
38	B04291	Electrical kit (1 element)	3 kw to 5 kw
39	B04292	Electrical kit (2 elements)	6 kw to 12 kw
40	A00421	Exterior probe wiring	
41	B04397	Control support	
42	L01F010	Transformer 208/240/24	
43	B04000-03	9 positions terminal	
-	L01G011	Fuse 2A	