



ALIZÉ

VARIABLE SPEED (AIR-TO-AIR) HEAT PUMP UNIT

Alizé



In order to increase the comfort benefit provided by our modulating furnaces, we developed our *Alizé* outdoor unit, an integrated part of our Right-Sized System[®] allowing variable speed cooling and heating.

The Right-Sized System[®] is a central warm air system with variable speed exclusive to Dettson. It is the combination of our *Alizé* heat pump unit with our Chinook gas furnace or our Supreme electric furnace.

Benefits and differentiators

- Side discharge unit
 - Very small footprint
 - Quiet outdoor operation (49 to 65 dB at full capacity)
- Longer operating cycles for better air mixing:
 - Uniform temperature for thermal comfort
 - Lower CFM
 - Quieter air distribution vs traditional overshoot excessive airflow
 - Better humidity control
- Low electrical consumption in both heating and cooling

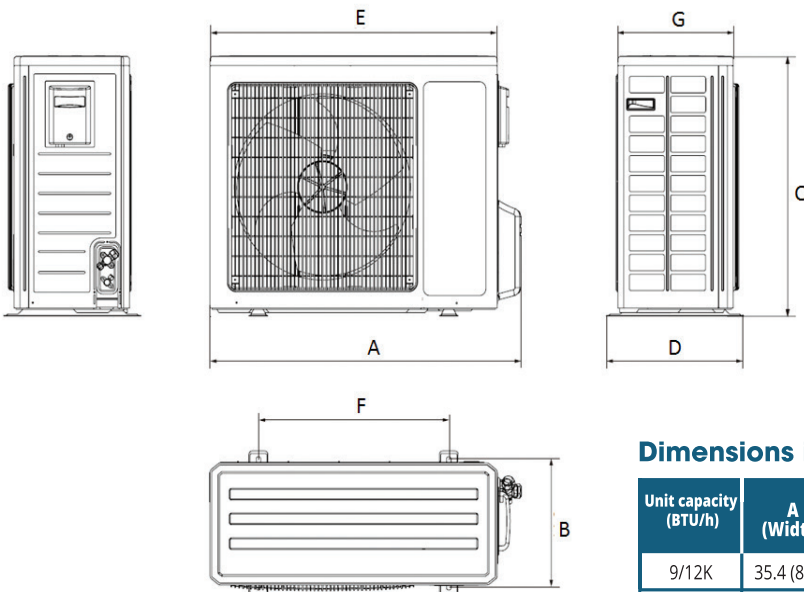

Product features

- Variable speed compressor, modulates from 25 to 100 %
- Capacities from 3/4 ton to 3 tons
- Specially designed fan blades for low drag, reducing fan noise to a minimum

Dimensions inches (cm)

Unit capacity (BTU/h)	A (Width)	B (Depth)	C (Height)	D	E	F	G
9/12K	35.4 (89.9)	13.9 (35.3)	23.5 (59.7)	14.9 (37.8)	33 (83.8)	21.7 (55.1)	11.9 (30.2)
18K	37.6 (95.5)	14.3 (36.3)	27.6 (70.1)	15.6 (39.6)	35 (88.9)	22 (55.9)	13.4 (34.0)
24K	38.6 (98.0)	15.6 (39.6)	31.1 (79.0)	16.8 (42.7)	36.2 (91.9)	24 (61.0)	14.6 (37.1)
30/36K	38.6 (98.0)	15.7 (39.9)	31.1 (79.0)	16.7 (42.4)	36 (91.4)	24 (61.0)	14.6 (37.1)

Specifications

MODEL		COND-09	COND-12	COND-18	COND-24	COND-30	COND-36
Power Supply		208/230V / 60Hz / 1 Phase					
Cooling capacity (min-max)	Btu/h	9000 (3500-9600)	12000 (3100-13000)	18000 (4600-20000)	24000 (6800-26000)	28000 (9500-30000)	33600 (7400-36000)
Heating capacity (min-max)	Btu/h	9800 (2200-11000)	13000 (2400-14000)	19000 (3400-20000)	25000 (7500-26000)	28400 (10000-33000)	34600 (15000-36000)
Rated current	A	9	9	11.1	16	16.7	18.2
EER	(Btu/h)/W	14.5	12.8	12	12	10.1	9.2
COP		3.8	3.5	3.5	3.3	2.9	2.9
SEER		27	25	21	21	16	16
HSPF		9	9	9.8	10	8.2	8.2
Throttling method		Electronic expansion valve					
Cooling operation ambient temperature range	° F (°C)	5/118.4 (-15/48)				40/109.4 (4/43)	
Heating operation ambient temperature range	° F (°C)	-4/86 (-20/30)				5/75.2 (-15/24)	
Defrosting method		Automatic defrosting					
Sound pressure level	dBA	49	49	56	56	62	65
Net weight	lb (kg)	86 (39)	87.1(39.5)	110.3 (50)	153 (70)	154.3 (70)	161 (73)
Refrigerant		R410A					
Refrigerant charge	oz	45.9	45.9	56.5	88.2	84.7	91.7
Precharged connection pipe length	ft (m)	24.6 (7.5)	24.6 (7.5)	24.6 (7.5)	24.6 (7.5)	24.6 (7.5)	24.6 (7.5)
Connection pipe gas additional charge	oz/ft.	0.2	0.2	0.5	0.5	0.5	0.5
Outer diameter liquid pipe	inch	φ1/4	φ1/4	φ1/4	φ1/4	φ1/4	φ1/4
Outer diameter gas pipe	inch	φ1/2	φ1/2	φ5/8	φ5/8	φ5/8	φ5/8
Max distance height	ft (m)	32.8 (10)	32.8 (10)	32.8 (10)	32.8 (10)	32.8 (10)	32.8 (10)
Max distance length	ft (m)	49.2 (15)	65.6 (20)	82 (25)	82 (25)	98.4 (30)	98.4 (30)