



HYDRA III

OUR SMALL ELECTRIC BOILER
WITH ELECTRONIC CONTROL

ELECTRONIC CONTROL

- Available from 3 to 29kW to meet all your needs : condos, single homes, multi-apartments or light commercial
- Multipositions : 6 installation options
- Light with mounting brackets included for ease of installation even in restricted space
- Perfect for heating floor, radiators and baseboard heaters
- Certified for copper or aluminium wiring
- Approved for 208/240V
- Standby function : the tank heats water only on demand



HYDRA III



Dimensions in inches

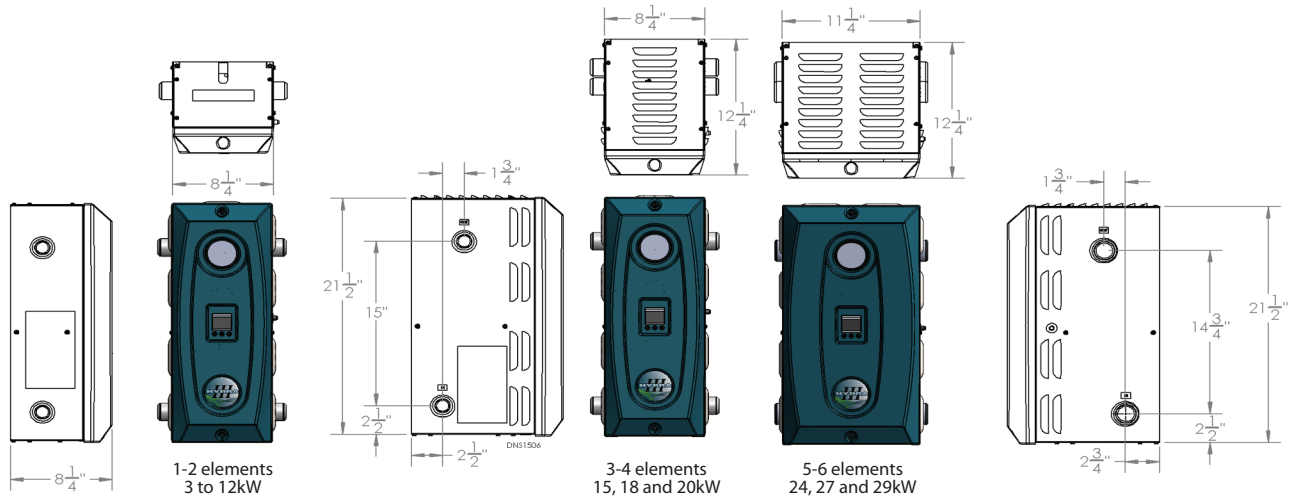

Electronic Control

- Presets for different applications : baseboard, light, cast iron and mass
- Setpoint, water and outdoor temperature display
- Pressure gauge
- Modulating control optimized to minimize cycling while keeping the setpoint stable
- Boost Mode : addition of 10°F (5.5°C) to setpoint for a period of 24 hours
- Adjustable high limit aquastat
- Displays outdoor and indoor temperature failures
- Integrated dual energy control for 15kW and over models
- Estimated electrical consumption display
- Circulator pump activated on heat demand, with off delay or continuous flow for temperature uniformity

	MODELS						
kW	3-12	15	18	20	24	27	29
Amperage*	12.5 - 50	63	75	83	100	113	121
kBTU**	10.8 - 43.3	51	61	68	82	92	99
Electrical Supply***	120/240V or 120/208V 1 phase (L1-N-L2)						
Weight	44 lb	65 lb		85 lb			
Inlet/Outlet Diameter	1" NPT			1 1/4" NPT			

*For 240V; for 208V multiply by 0.867

Refer to local standard norms for the choice of the breaker

**For 240V; for 208V multiply by 0.75

***3 conductors 90°C with ground or 2 conductors power with ground if the application does not require power to a 120 VAC pump or accessories

Piping installation options



3400, boulevard Industriel
Sherbrooke, Québec
J1L 1V8 Canada

T 1.819.346.8493
TF 1.800.567.2733
F 1.819.822.4227
info@dettson.ca
www.dettson.ca