

NORTRON

INSTALLATION AND USER MANUAL

ECM SERIES ELECTRIC FURNACE

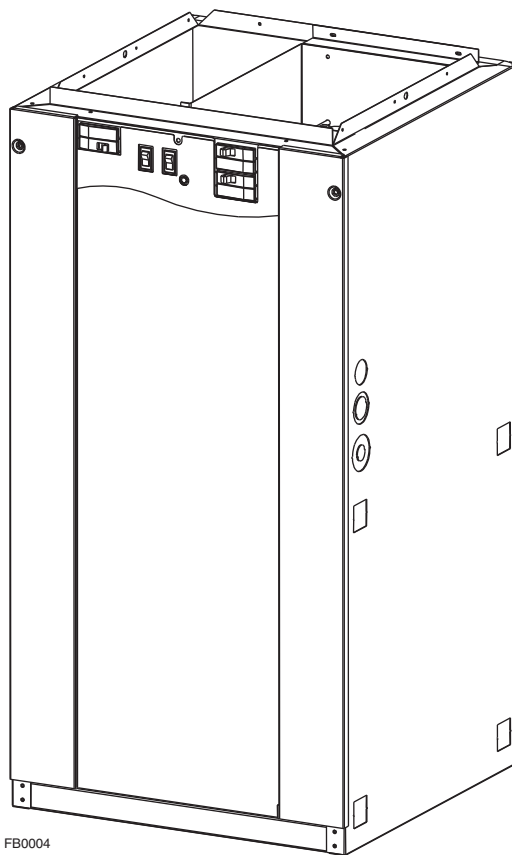

MODELS: 21ECM10, 21ECM15, 21ECM18, 21ECM20 AND 21ECM23

IMPORTANT: READ AND SAVE THESE INSTRUCTIONS.

NORTRON; Sherbrooke, Quebec www.dettson.ca 800-567-2733

30042525B

⚠ WARNING

- Never tamper with the unit or its controls. User **MUST** contact a specialized contractor when a failure occurs. **DO NOT ATTEMPT** to repair.
- When using a humidifier make sure not to damage the heating element bank.
- We recommend that your unit be inspected by a specialized technician once a year.
- Poor maintenance of air filters OR an unbalanced static pressure may result in a performance decrease.
- Always use genuine parts for maintenance or service call. The use of unbranded parts will void the warranty.
- The use of this unit without an air distribution duct will void the warranty.
- It is strictly forbidden to use jumpers to simulate heat demand.
- Risk of electrical shock. Disconnect power before installation, servicing, maintenance or field wiring. Replace all panels before operating. Failure to do so can result in electrical shock causing severe injuries or death.
- When performing installation, servicing or cleaning the unit, it is recommended to wear safety glasses and gloves.
- To assure a proper performance of your furnace, we recommend that you use high quality name brand thermostats.
- When applicable local regulation comprises more restrictive installation and/or certification requirements, the aforementioned requirements prevail on those of this document and the installer agrees to conform to these at his own expenses.
- For your safety, do not store or use gasoline or other flammable liquids and vapors in the vicinity of this unit or any other appliance.
- These instructions are intended to be used by qualified personnel who have been trained in installing this type of furnace. Installation of this furnace by an unqualified person may lead to equipment damage and/or hazardous condition which may lead to bodily harm.
- This furnace is not watertight and is not designed for outdoor installation. This furnace shall be installed in such a manner as to protect its electrical components from water. Outdoor installation leads to a hazardous electrical condition and to premature furnace failure, thus voiding the warranty.
- Do not block the combustion air openings in the furnace. Any blockage will result in improper overheat situation and may result in a fire hazard and/or cause bodily harm.
- The unit must have an uninterrupted or unbroken electrical ground to minimize personal injury if an electrical fault should occur. When performing electrical connection, the ground conductor must be firmly attached to the ground lug in the furnace.
- Do not use this furnace as a construction heater. Use of this furnace as a construction heater exposes the furnace to abnormal conditions, contaminated combustion air and the lack of air filters. Failure to follow this warning can lead to premature furnace failure and/or vent failure which could result in a fire hazard and/or bodily harm.
- The owner and/or the user is responsible of the following: Always maintain the immediate surrounding of the furnace free from combustible and highly flammables materials. The furnace ambient air should not have an excessive dust concentration and humidity. Never operate this central heating appliance without an air filter.
- Before performing any service functions, unless operations specifically require the power to be on, make sure all utilities are turned "OFF" upstream of the appliance. Failure to comply with this warning will cause a fire hazard and/or bodily harm.
- All questions regarding the operation, maintenance or warranty of this unit should be addressed to the company where this product has been sold from.

CAUTION

- Never burn garbage or paper in the heating system and never leave rags or paper around the unit.
- Return air grilles and warm air registers must not be obstructed.

IMPORTANT: All local and national code requirements governing the electrical installation heating equipment, wiring and flue connections must be followed. Some of the codes that may be applicable are :

ANSI/NFPA 70 NATIONAL ELECTRICAL CODE

CSA C22.1 CANADIAN ELECTRICAL CODE

Only the latest issues of the above codes should be used, and are available from either:

The National Fire Protection Agency
Batterymarch Park
Quincy, MA 02269

or

The Canadian Standards Association
178 Rexdale Blvd.
Rexdale, Ontario M9W 1R3

TABLE OF CONTENTS

1. DIMENSIONS	3
2. GENERAL REQUIREMENTS AND SPECIFICATIONS	4
3. OPERATING OPTIONS	5
4. BREAKERS	5
5. INSTALLATION NOTES	6
5.1 COLD AIR RETURN	6
5.2 ELECTRICAL WIRING - POWER SUPPLY	6
5.3 CONNECTING AND ADJUSTING THE LOW VOLTAGE THERMOSTAT	6
6. USE IN MOBILE HOMES	6
7. USING OPTIONAL EQUIPMENT	7
7.1 TWO-STAGE OR OUTDOOR THERMOSTAT	7
7.2 AIR CONDITIONING	7
7.3 ELECTRONIC AIR CLEANERS AND/OR POWERED FURNACE HUMIDIFIERS	7
7.4 INTERLOCK CONNECTION	7
8. WIRING DIAGRAMS	8-9
9. SERVICE PARTS	10
10. MAINTENANCE	11
11. TROUBLESHOOTING	11
12. WARRANTY	12

1. DIMENSIONS

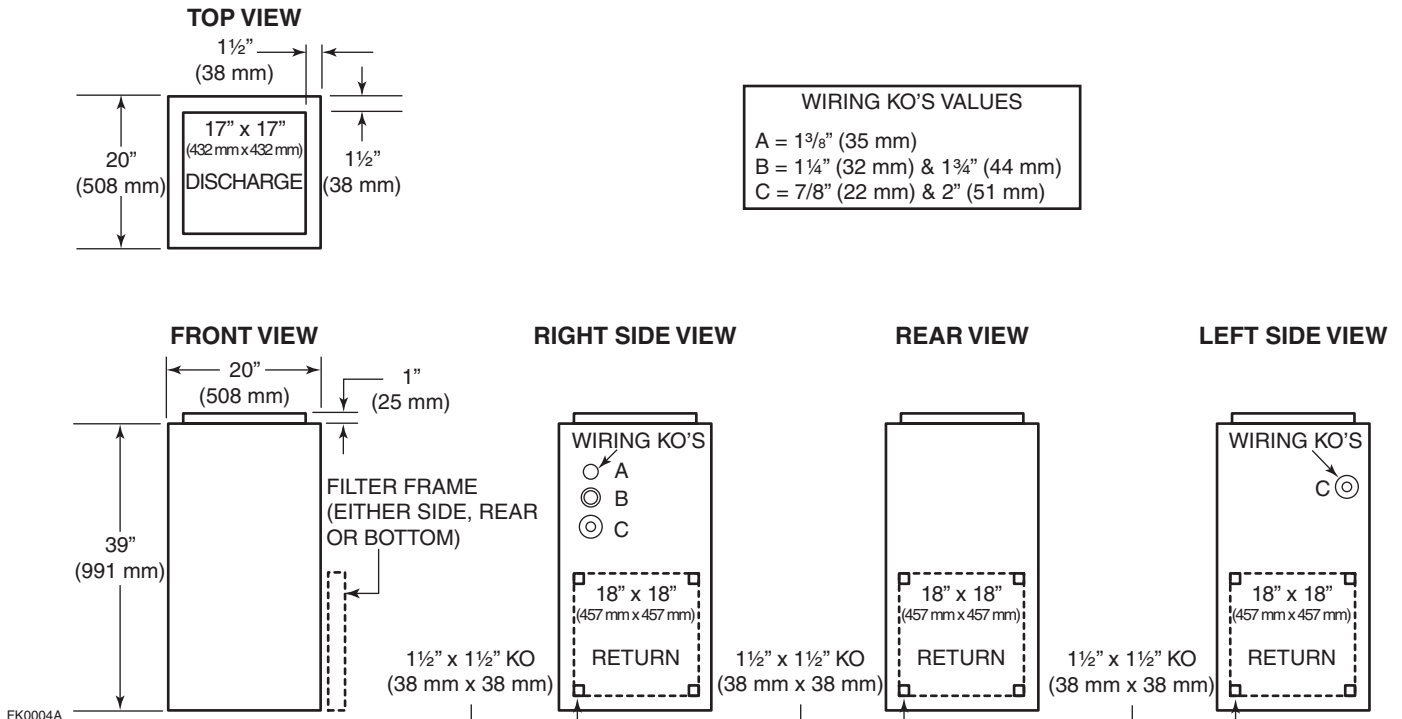

2. GENERAL REQUIREMENTS AND SPECIFICATIONS

CAUTION

This unit must be installed in a dry place, in a non-corrosive, well-ventilated environment, without excessive dust. The ambient temperature must be over 10°C and under 27°C. If the ambient temperature is 10°C or less, the plenum must be insulated on 10 ft linear minimum length.

1. LOCATION - The furnace should be centrally located to the heating area.
2. POSITIONS - It can be installed for vertical, horizontal or downflow operation. When installed horizontally, the furnace should be positioned such as the door will not end up being on the top. The door should be on the side of the furnace, to ensure that the motor bearings are in their designed position. In vertical downflow installations, use only "L"- or "T"-shaped plenum with no openings or registers directly below furnace.
3. INSTALLATION CLEARANCES - As shipped from the factory, each unit is approved for "zero inch" clearance. If additional clearance is required, it will be indicated on the data label attached to the furnace.
4. TEMPERATURE RISE - Furnaces are shipped to operate at 0.20" W.C. (50 Pa) external static pressure. They are certified for operation up to 0.50" W.C. (125 Pa). Check below for temperature rise table on specification chart and, if necessary, adjust the unit to match.
5. SERVICE CLEARANCE - Units are serviced from the FRONT. Leave at least 24" (610 mm) clearance in front of the door.

240 VOLTS - SINGLE PHASE						TEMPERATURE RISE @ 0.20" W. C.			
MODEL NO.	KW	BTHU	AMPS INCL. MOTOR	HP	BLOWER	°C	°F	*SPEED	RPM
21ECM10	10	34152	43	1/3	10" x 8" (254 mm x 203 mm)	22	40	LOW	662
21ECM15	15	51228	64	1/3		22	40	MEDIUM	903
21ECM18	18	61473	76	1/3		26	47	MEDIUM	903
21ECM20	20	68304	84	1/3		29	52	MEDIUM	903
21ECM23	22.5	76842	94	1/3		36	65	MEDIUM	903

*FACTORY SETTINGS.

SUBJECT TO CHANGE WITHOUT NOTICE.

10" x 8" (254 mm x 203 mm) BLOWER						
SPEED	FLOW RATE	STATIC PRESSURE (INCHES OF WATER COLUMN)				
		0.2	0.3	0.4	0.5	0.6
LOW**	CFM	684	582	535	481	429
	L/s	323	275	252	227	202
MEDIUM	CFM	1149	1104	1064	1016	977
	L/s	542	521	502	479	461
HIGH	CFM	1238	1203	1174	1139	1106
	L/s	584	568	554	538	522

** This speed can only be run with heater off, for cooling/ventilation purposes only.

3. OPERATING OPTIONS

The furnace is shipped from the factory in a "Standard Heating Mode" (all switches are in the Down position). When the thermostat calls for heat, the automatic controls will be activated and the furnace turned "ON".

The blower will run at low speed or higher speed (as selected by **SPEED SELECTOR** switch).

As the furnace heats up, it automatically switches to the pre-programmed heating speed when additional elements are activated by the electronic control, if it was initially set to run at low speed. The timing of this blower speed change will depend on whether **FAST** or **SLOW** is selected on the **HEAT ACTIVATION** switch.

You may, however, change from the Standard Heating Mode by using the controls built into your furnace.

SPEED SELECTOR



HEAT ACTIVATION

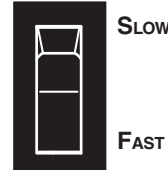

The **SPEED SELECTOR** switch is used to control the fan speed (ventilation). Even if there is no call for heat, the ventilation can be controlled by the thermostat; the fan speed is determined by this switch.

LOW – The blower motor will operate at low speed.

HIGH – The blower motor will operate at a higher speed.

During spring or fall, you may require less rapid response when the thermostat calls for heat.

When **SLOW** is selected, it takes more time to bring all the elements online.

When **FAST** is selected, the heating elements come online faster.

Slow (First Stage) Slow Response Sequence	Fast (Second Stage) Rapid Response Sequence
Element 1 - Heat on instantly	Element 1 - Heat on instantly
Blower on after a 3-second delay	Blower on after a 3-second delay
Elements 3 and 5 after a 1-minute delay	Elements 3 and 5 after a 10-second delay
Element 2 after a 2-minute delay	Element 2 after a 20-second delay
Element 4 after a 3-minute delay	Element 4 after a 30-second delay

NOTE: Elements 4 and 5 only where applicable.

4. BREAKERS

ECM Series furnaces are equipped with breakers, located on the front panel of the unit. These devices protect the heating elements from overcurrent. If this situation occurs, the breakers will open to cut the power from the heating elements only.

NOTE: The number of breakers varies according to the furnace model; 21ECM10 model has no breakers, 21ECM15, 21ECM18 and 21ECM20 models have 2 breakers and 21ECM23 model has 3 breakers. Refer to Section 8 Wiring Diagrams.

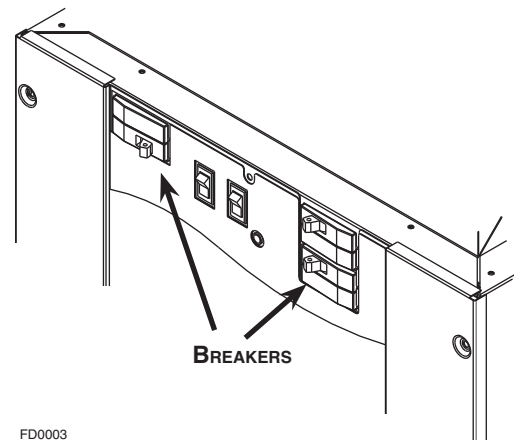

FD0003

⚠ WARNING

Breakers do not cut power to entire furnace, only to the heating elements. Do not use the breakers to turn off the furnace. The power to the whole unit can only be cut from the main electrical panel.

5. INSTALLATION NOTES

5.1 COLD AIR RETURN

The duct can be attached to either side, rear or the bottom of the furnace.

For side return there are four 1½" (38 mm) knockouts which can be removed and used as an outline for cutting a 18" x 18" (457 mm x 457 mm) return air opening in the furnace left or right side. Mount the filter frame to the furnace over the opening with the open side of the frame facing front. Then attach the 19" x 19" (483 mm x 483 mm) air duct to the flanges on the filter frame.

For bottom mounting, remove the screws holding the bottom plate to the furnace, discard the bottom plate and attach the filter frame to the bottom flanges with the open side of the frame facing front.

5.2 ELECTRICAL WIRING - POWER SUPPLY

The furnaces are completely factory wired. From a separate breaker, a two-wire plus ground supply wire is required. The ground conductor must be firmly attached to the ground lug in the furnace and the supply wires to the terminal block in the furnace.

NOTE: When a FK120 ECM kit is used to supply an air cleaner and/or humidifier, a third (neutral) conductor must be brought into the furnace.

⚠ WARNING

For all installations, we only recommend appropriate gauge good quality copper wire(s). However, it is the electrician's responsibility to ensure that the wiring and connections are compliant to the latest editions of the Canadian Electrical Code and local codes.

5.3 CONNECTING AND ADJUSTING THE LOW VOLTAGE THERMOSTAT (Use only class 1 wires inside furnace compartments.)

Attach thermostat wires to the low voltage terminal block located on the inside of the furnace. Follow the diagrams supplied with the thermostat. As a general guide, remember that the R & W terminals control single stage heating; the R & Y terminals control cooling. Single stage cooling uses "Y/Y2" as first and only stage. Two-stage cooling uses "Y1" as first stage and "Y/Y2" as second stage. Make sure the thermostat is levelled on the wall and in appropriate location as per instructions supplied with the thermostat.

CAUTION

Before turning the furnace on, the heat anticipator in the thermostat must be properly set.

Because each installation is different an accurate reading of the current draw should be made with an AC meter. Set the meter at 2 A range for furnaces through 20 kW, and at 4 A range for larger units.

- Set the anticipator at its highest setting.
- Disconnect the "W1" thermostat wire from the furnace low voltage terminal connections.
- Connect the AC meter between the "W1" terminal on the board and the loose "W1" wire.
- Turn the thermostat up to start the furnace and allow it to run, with all elements on, for three or four minutes.
- Read the current draw on the meter and reset the anticipator to match the meter reading.

6. USE IN MOBILE HOMES

Models 21ECM10, 21ECM15, 21ECM18 & 21ECM20 are certified for "L"-shape and "T"-shape shallow duct installation with model FSB-1 sub-base in downflow applications when the supply air ducts pass through the floor of the structure. Recommended size of a floor opening: 14¼" x 14¼" (362 mm x 362 mm). The duct system must be designed so that the external static pressure of the system does not exceed the maximum external static pressure of 0.50" W.C. (125 Pa).

SHALLOW DUCT AREA REQUIREMENTS	
DUCT DEPTH	DUCT WIDTH
4" (102 mm)	16" (406 mm)
5" (127 mm)	13" (330 mm)
6" (152 mm)	10" (254 mm)

7. USING OPTIONAL EQUIPMENT

7.1 TWO-STAGE OR OUTDOOR THERMOSTAT

(The **HEAT ACTIVATION** switch must be in the **Slow** position).

Follow the directions supplied with the two-stage or outdoor thermostat in conjunction with the furnace wiring diagram.

7.2 AIR CONDITIONING

Your furnace is equipped with all the controls required for the addition of air conditioning (except the heat-cool thermostat).

The evaporator coil may be installed by a local contractor in sheet metal plenum of his own manufacture. The coil should be located: centred over the "chimney" of the furnace 4" (102 mm) to 6" (152 mm) above the top of the furnace.

Make sure no air is allowed to bypass the cooling coil during cooling operation. If the discharge opening is a great deal larger than the coil, and the ductwork is correspondingly larger than the coil, you may want to use a bypass damper for heating. The damper would be closed in summer, directing all air flow through the coil. In winter the damper would be open to allow air to bypass the coil.

Typical air-conditioning field wiring connections are shown in the diagram at right.

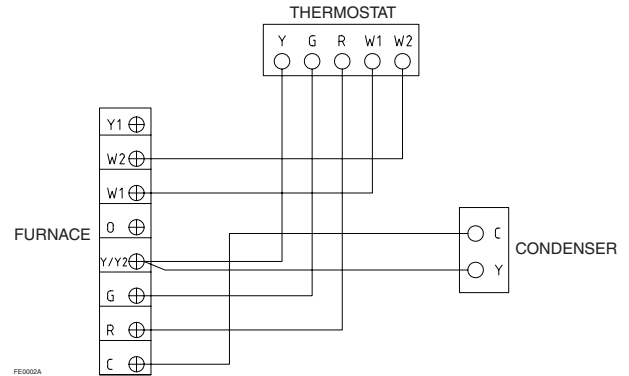

WIRING COLOR CODE					
C	G	R	W1	W2	Y
COMMON	GREEN	RED	WHITE	WHITE (BLUE OPTIONAL)	YELLOW

7.3 ELECTRONIC AIR CLEANERS AND/OR POWERED FURNACE HUMIDIFIERS

These units operate at 120 V. Your 240 V furnace is designed so that Model FK120 ECM adaptor kit can be mounted inside the furnace to supply the required 120 V. Instructions for mounting and wiring are included with the kit.

7.4 INTERLOCK CONNECTION

When the electric furnace is used in combination with another device (as for example, a wood burning furnace), it is recommended to perform the connection by referring to the wiring diagram at right. The burning furnace thermostat will then turn automatically on the blower in the electric furnace.

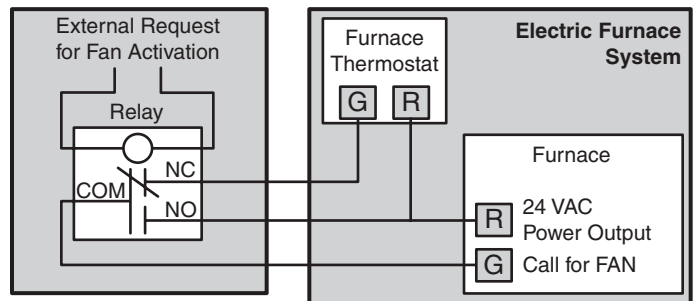

FE0034A

8. WIRING DIAGRAMS

⚠ WARNING

Risk of electric shock. Disconnect power before installation, servicing, maintenance or field wiring. Replace all panels before operating. Failure to do so can result in electric shock causing severe injuries or death.

21ECM10 Model

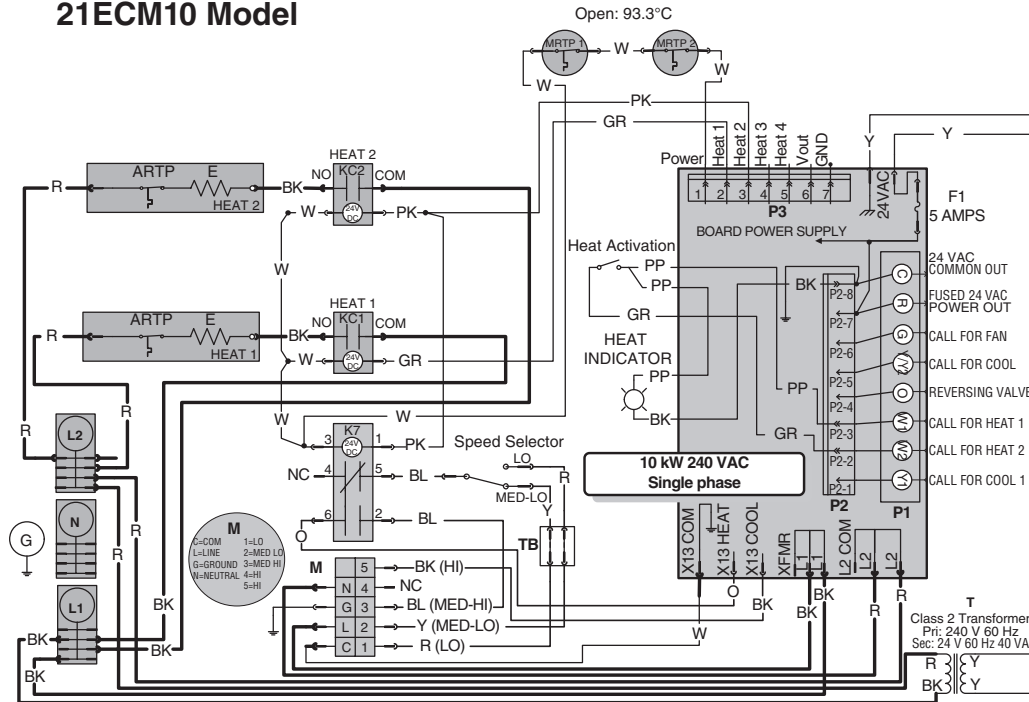

Critical characteristic

1. If any of the original wire, as supplied, must be replaced, use the same equivalent wire. Wiring must comply with applicable codes, ordinances and regulations.
2. Field wiring must comply with applicable codes, ordinances and regulations. Use only Class 1 wiring inside furnace compartments.

Line voltage wiring:
 UL AWM 1015, 600V, 105°C, VW-1, 8 AWG;
 UL AWM 1015/1230, 600V, 105°C, VW-1, 12 AWG;
 CSA TEW 600V, 105°C, FT-1, 8 AWG, 12 AWG.

Low voltage wiring:
 same ratings as high voltage except 18 AWG.

FAN MOTOR SPEED	COLOR
HI	BLACK
MED-HIGH	BLUE
MED-LOW	YELLOW
LOW	RED

21ECM15 Model

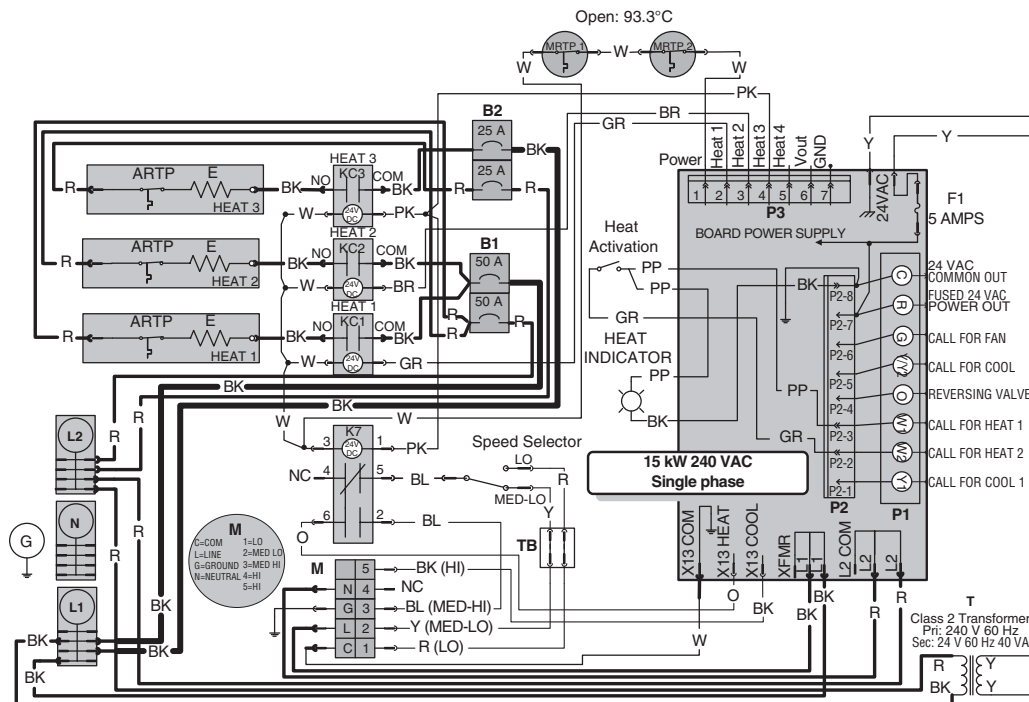

LEGEND

C	Capacitor
E	Heating Element
KC	Heating Element Relay
K	Fan Relay
ARTP	Auto-Reset Thermal Protector
MRTP	Manual-Reset Thermal Protector
M	Fan Motor
TB	Terminal Block
T	Transformer Class 2
HEAT	Heat
L1, L2	240 V Line Supply
N	Neutral
F1	Fuse
B	Breaker

Low power
 High power
 High power 8 AWG

WIRING COLOR CODE

BK	BLACK
BL	BLUE
BR	BROWN
GR	GREY
O	ORANGE
PK	PINK
PP	PURPLE
R	RED
W	WHITE
Y	YELLOW

For the use of a two-stage thermostat or an outdoor thermostat, connect between W1 and W2. Make sure that the Heat Activation switch is set to "Slow" position.

8. WIRING DIAGRAMS (CONT'D)

⚠ WARNING

Risk of electric shock. Disconnect power before installation, servicing, maintenance or field wiring. Replace all panels before operating. Failure to do so can result in electric shock causing severe injuries or death.

21ECM18 & 21ECM20 Models

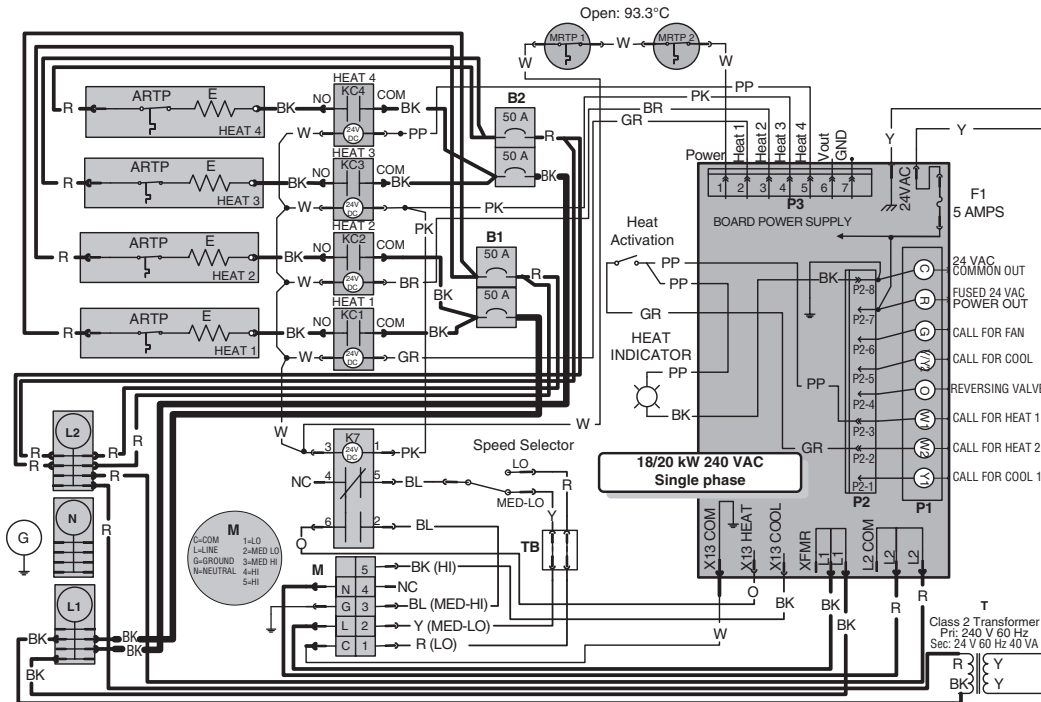

Critical characteristic

- If any of the original wire, as supplied, must be replaced, use the same equivalent wire. Wiring must comply with applicable codes, ordinances and regulations.
- Field wiring must comply with applicable codes, ordinances and regulations. Use only Class 1 wiring inside furnace compartments.

Line voltage wiring:
 UL AWM 1015 600V, 105°C, VW-1, 8 AWG;
 UL AWM 1015/1230, 600V, 105°C, VW-1, 12 AWG;
 CSA TEW 600V, 105°C, FT1, 8AWG and 12 AWG.

Low voltage wiring:
 same ratings as high voltage except 18 AWG.

FAN MOTOR SPEED	COLOR
HI	BLACK
MED-HI	BLUE
MED-LOW	YELLOW
LOW	RED

LEGEND	
C	Capacitor
E	Heating Element
KC	Heating Element Relay
K	Fan Relay
ARTP	Auto-Reset Thermal Protector
MRTP	Manual-Reset Thermal Protector
M	Fan Motor
TB	Terminal Block
HEAT	Heat
L1, L2	240 V Line Supply
N	Neutral
F1	Fuse
B	Breaker

Low power	—
High power	—
High power 8 AWG	—

WIRING COLOR CODE	
BK	BLACK
BL	BLUE
BR	BROWN
GR	GREY
O	ORANGE
PK	PINK
PP	PURPLE
R	RED
W	WHITE
Y	YELLOW

For the use of a two-stage thermostat or an outdoor thermostat, connect between W1 and W2. Make sure that the Heat Activation switch is set to "Slow" position.

21ECM23 Model

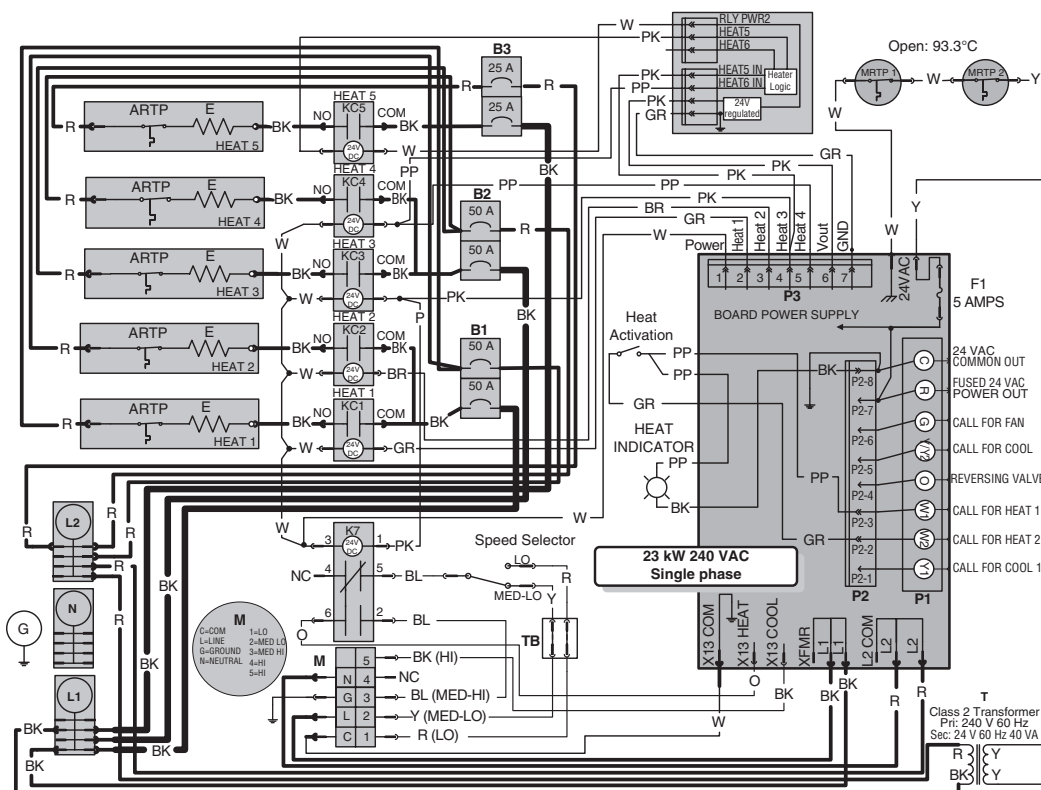

FE0067A

9. SERVICE PARTS

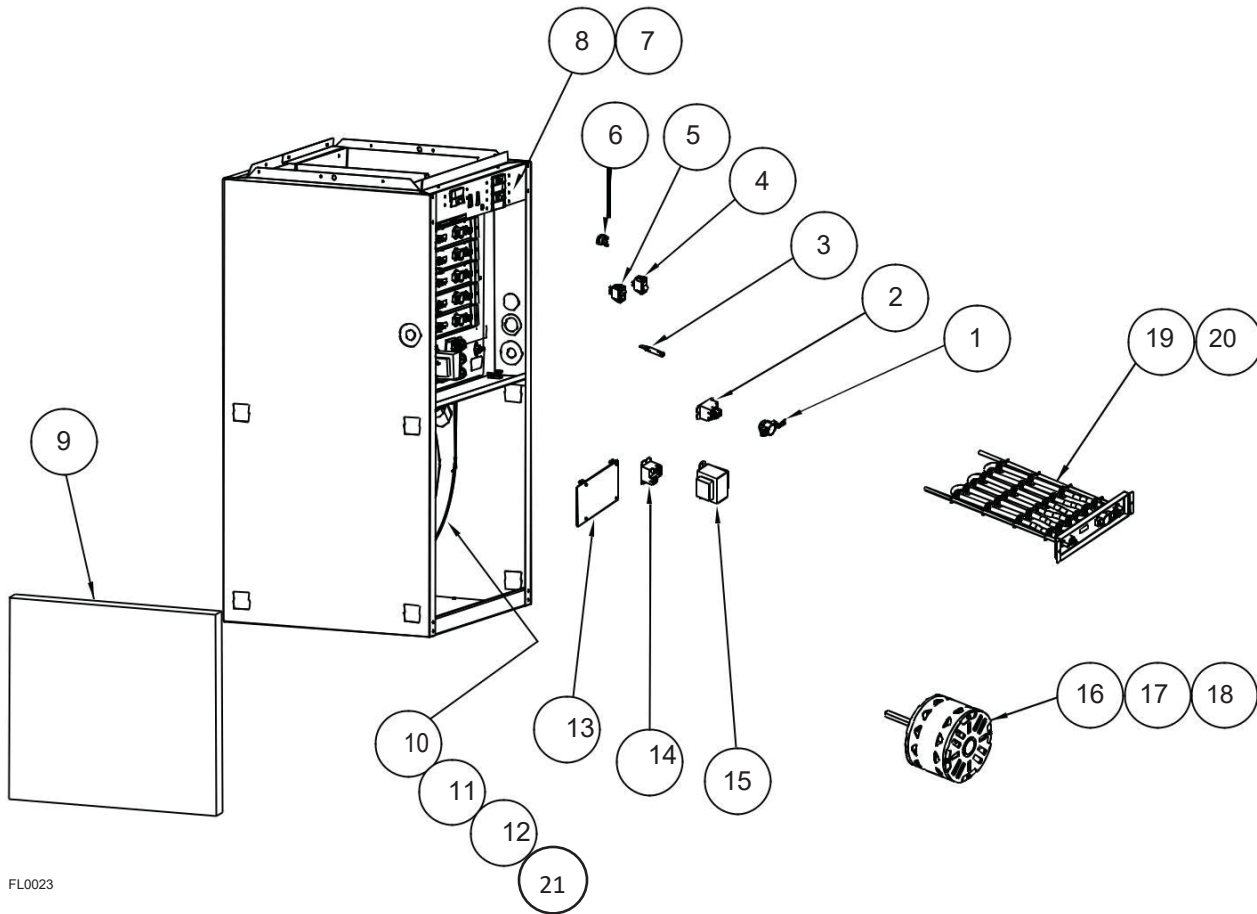

FL0023

REPLACEMENT PARTS		
KEY NO.	PART NO.	DESCRIPTION
1	30270032	Automatic Limit
2	30274132	Relay (KC1, KC2, KC3, KC4 and KC5)
3	30280021	Thermostat Indicator Light
4	30030006	Heat Activation Switch
5	30030025	Speed Selection Switch
6	30280020	Manual Reset Limit
7	30274200	Breaker 50 Amps
8	30274199	Breaker 25 Amps
9	30010010	Fiberglass Filter 20" x 20" x 1" (508 mm x 508 mm x 25 mm)
10	10941385	Service Blower Assembly for 21ECM10
11	10941291	Service Blower Assembly for 21ECM15
12	10941292	Service Blower Assembly for 21ECM18 21ECM20 and 21ECM23

REPLACEMENT PARTS		
KEY NO.	PART NO.	DESCRIPTION
13	624665	Electronic Control
14	30274131	Relay (K7)
15	30300022	Transformer 240 V
16	10941384	Motor 1/3 HP 208/230 V for 21ECM10
17	10941289	Motor 1/3 HP 208/230 V for 21ECM15
18	10941290	Motor 1/3 HP 208/230 V for 21ECM18, 21ECM20 and 21ECM23
19	10940080	Element Assembly 5000 W, 240 V
20	10940081	Element Assembly 4500 W, 240 V
21	30390119	Blower Housing & Wheel DD10
*	10941367	Service Wiring Kit "ECM"
*	624664	Daughterboard (21ECM23 only)
*	10941442 10941443	Service Door ECM Series ^{10-20KW} _{23KW}
*	FK120 ECM	120 Volt Kit (optional, purchase separately)

* Not illustrated

REPLACEMENT PARTS AND REPAIRS

IN ORDER TO ENSURE YOUR UNIT REMAINS IN GOOD WORKING CONDITION, YOU MUST USE NORTRON GENUINE REPLACEMENT PARTS ONLY. THE NORTRON GENUINE REPLACEMENT PARTS ARE SPECIALLY DESIGNED FOR EACH UNIT AND ARE MANUFACTURED TO COMPLY WITH ALL THE APPLICABLE CERTIFICATION STANDARDS AND MAINTAIN A HIGH STANDARD OF SAFETY. ANY THIRD PARTY REPLACEMENT PART USED MAY CAUSE SERIOUS DAMAGE AND DRASTICALLY REDUCE THE PERFORMANCE LEVEL OF YOUR UNIT, WHICH WILL RESULT IN PREMATURE FAILING. ALSO NORTRON RECOMMENDS TO CONTACT A CERTIFIED SERVICE DEPOT FOR ALL REPLACEMENT PARTS AND REPAIRS.

10. MAINTENANCE

MOTOR: The motor is lubricated for life and needs no oiling.

FILTERS: Size is 20" x 20" x 1" (508 mm x 508 mm x 25 mm). Should be inspected and replaced when dirty. Ordinarily replacement is required twice per heating season and, perhaps, a third time if continuous blower operation is used.

NOTE: Each element has an automatic reset thermal cut-out which is set to open at 160°F (71°C). If it opens, the element will be de-energized until the cut-out resets itself. In addition to that, there are 2 manual reset thermal cut-outs that open at 200°F (93°C). If any of them open, a front panel needs to be removed so the cut-out can be manually reset.

⚠ WARNING

Cut 240 V power supply before removing the front panel!

11. TROUBLESHOOTING

The first step in identifying an operational problem is to determine whether the fault is in the furnace or in the thermostat and/or its connecting wiring.

To help make this determination, the furnace is equipped with a "Thermostat ON" diagnostic light. If the light is "ON," it indicates the thermostat has closed and is calling for heat; the blower should be operating. If the light is "OFF," the furnace should not be operating.

1. If the furnace will not start:

Turn the thermostat to its highest setting. If the light goes on, the thermostat has closed, so the fault is in the furnace. If the light does not go on, the thermostat or its connecting wiring is the problem.

2. If the furnace will not turn off:

Turn the thermostat to its lowest setting. If the light goes off and the furnace continues to run, the thermostat has opened properly and the problem resides in the furnace. If the light stays on, the fault is in the thermostat or its connecting wiring.

After the fault area is isolated by use of the diagnostic light, a check of the following components can be made more efficiently.

PROBLEM	POSSIBLE DEFECTIVE PARTS OR COMPONENTS
1. The furnace will not turn on.	<ul style="list-style-type: none"> • Thermostat • Circuit breaker or fuse is open • SPEED SELECTOR switch (open contact) • Electronic control • Transformer
2. Motor runs continuously.	<ul style="list-style-type: none"> • Thermostat wires incorrectly attached to the furnace
3. Elements on, but motor does not run.	<ul style="list-style-type: none"> • Motor or capacitor • SPEED SELECTOR switch (open contact) • Electronic control
4. Motor going on and off in short cycles (or in too long cycles)	<ul style="list-style-type: none"> • Heat anticipator in thermostat incorrectly set or may be defective
5. The thermostat must be set much higher (or lower) than the desired house temperature	<ul style="list-style-type: none"> • The thermostat is not leveled or out of calibration
6. Not enough heat	<ul style="list-style-type: none"> • One or more defective elements or sequencers • HEAT ACTIVATION switch set in Low position • Safety limits opening because duct obstruction or dirty filters are restricting air flow • Defective or incorrect wired two-stage or outdoor thermostat • Lack of enough cold air returns in house
7. Two-stage or outdoor thermostat not operating properly	<ul style="list-style-type: none"> • HEAT ACTIVATION switch not set in Low position
8. Thermal cut-out opens	<ul style="list-style-type: none"> • Airflow is reduced because of blocked ductwork or very dirty filters
9. Breaker on front panel trips	<ul style="list-style-type: none"> • Overcurrent on heating element. Reset the breaker. If problem persists, call an electrician

12. WARRANTY

NORTRON

SIXTY-MONTH LIMITED WARRANTY FOR NORTRON PRODUCTS

Nortron warrants to the original consumer purchaser of Nortron products that such products will be free from defects in materials or workmanship for a period of sixty (60) months from the date of original purchase. THERE ARE NO OTHER WARRANTIES, EXPRESS OR IMPLIED, INCLUDING, BUT NOT LIMITED TO, IMPLIED WARRANTIES OR MERCHANTABILITY OR FITNESS FOR A PARTICULAR PURPOSE.

During this sixty-month period, Nortron will, at its option, repair or replace without charge, any product or part which is found to be defective under normal use and service. This product or part should be shipped prepaid by the customer to the company factory or the nearest authorized service center.

THIS WARRANTY DOES NOT EXTEND TO FILTERS, FURNACE KITS SOLD SEPARATELY, DUCTS, AND ACCESSORIES FOR DUCTING. This warranty does not cover (a) normal maintenance and service or (b) any products or parts which have been subject to misuse, negligence, accident, improper maintenance or repair (other than by Nortron), faulty installation or installation contrary to recommended installation instructions. Nortron does not accept any responsibility for transportation of repaired part or replaced product mentioned above and for reinstallation costs.

The duration of any implied warranty is limited to the sixty-month period as specified for the express warranty. Some jurisdictions do not allow limitation on how long an implied warranty lasts, so the above limitation may not apply to you.

NORTRON'S OBLIGATION TO REPAIR OR REPLACE, AT NORTRON'S OPTION, SHALL BE THE PURCHASER'S SOLE AND EXCLUSIVE REMEDY UNDER THIS WARRANTY. NORTRON SHALL NOT BE LIABLE FOR INCIDENTAL, CONSEQUENTIAL OR SPECIAL DAMAGES ARISING OUT OF OR IN CONNECTION WITH PRODUCT USE OR PERFORMANCE. Some jurisdictions do not allow the exclusion or limitation of incidental or consequential damages, so the above limitation or exclusion may not apply to you.

This warranty gives you specific legal rights, and you may also have other rights, which vary from province to another. This warranty supersedes all prior warranties, and applies only in Canada territorial limits.

To qualify for warranty service, you must (a) notify Nortron at the address or telephone number stated below, (b) give the model number and part identification and (c) describe the nature of any defect in the product or part. At the time of requesting warranty service, you must present evidence of the original purchase date.

NORTRON; 3400 Boul. Industriel, Sherbrooke, QC J1L 1V8

www.dettson.ca

800-567-2733